



REPAIR PARTS MANUAL
MODEL NO. RELTS3611A
Lawn Tractor

Rally

HOW TO USE THIS MANUAL

This manual is designed to provide the customer with a means to identify the parts on his/her tractor when ordering repair parts. The illustrations may or may not represent the actual assemblies; therefore, it is not recommended to use this manual as a guide to assemble or disassemble the tractor. Some hardware and parts are drawn larger in order to more readily identify them.

Each tractor has its own model number.

The model number for your tractor can be found on the fender under the seat.

When ordering parts, always give the following information:

- Product - "Lawn Tractor"
- Model Number - "RELTS3611A"
- Part Number
- Part Description

TABLE OF CONTENTS

SCHEMATIC	3
ELECTRICAL	4-5
CHASSIS AND ENCLOSURES	6-7
DRIVE	8-9
STEERING	10-11
ENGINE	12
SEAT	13
DECALS	14
MOWER LIFT	15
MOWER DECK	16-17

TRACTOR - - MODEL NUMBER RELTS3611A

SCHEMATIC

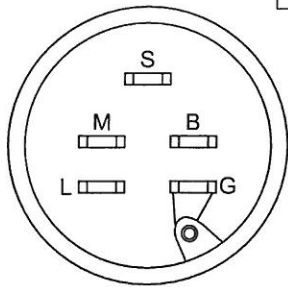
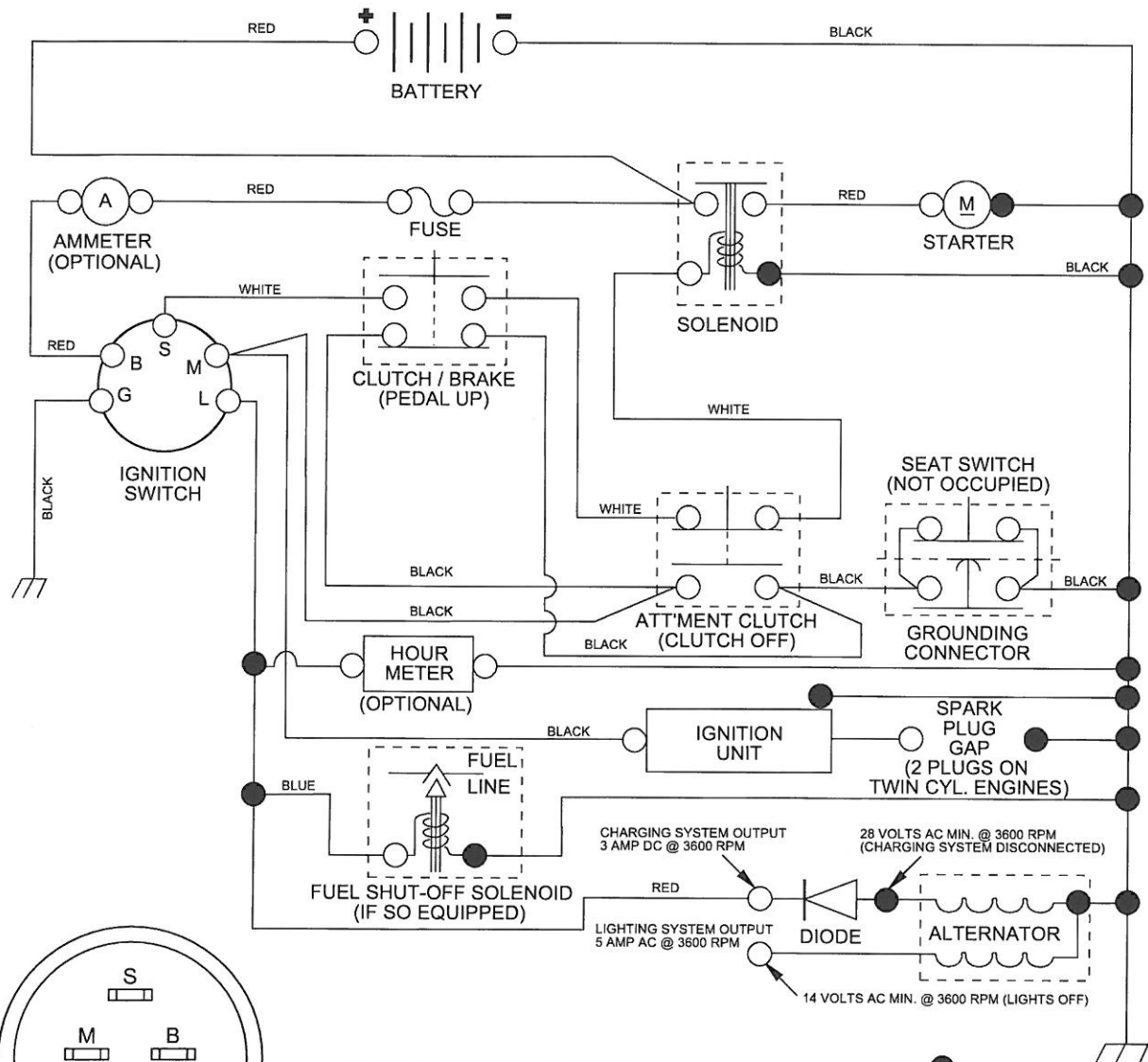

IGNITION SWITCH

POSITION	CIRCUIT
OFF	M + G
ON	B + L
START	B + S + L

WIRING INSULATED CLIPS
NOTE: IF WIRING INSULATED CLIPS WERE REMOVED FOR SERVICING OF UNIT, THEY SHOULD BE REPLACED TO PROPERLY SECURE YOUR WIRING.

●
NON-REMOVABLE CONNECTIONS

○
REMOVABLE CONNECTIONS

REPAIR PARTS

TRACTOR - - MODEL NUMBER RELTS3611A

ELECTRICAL

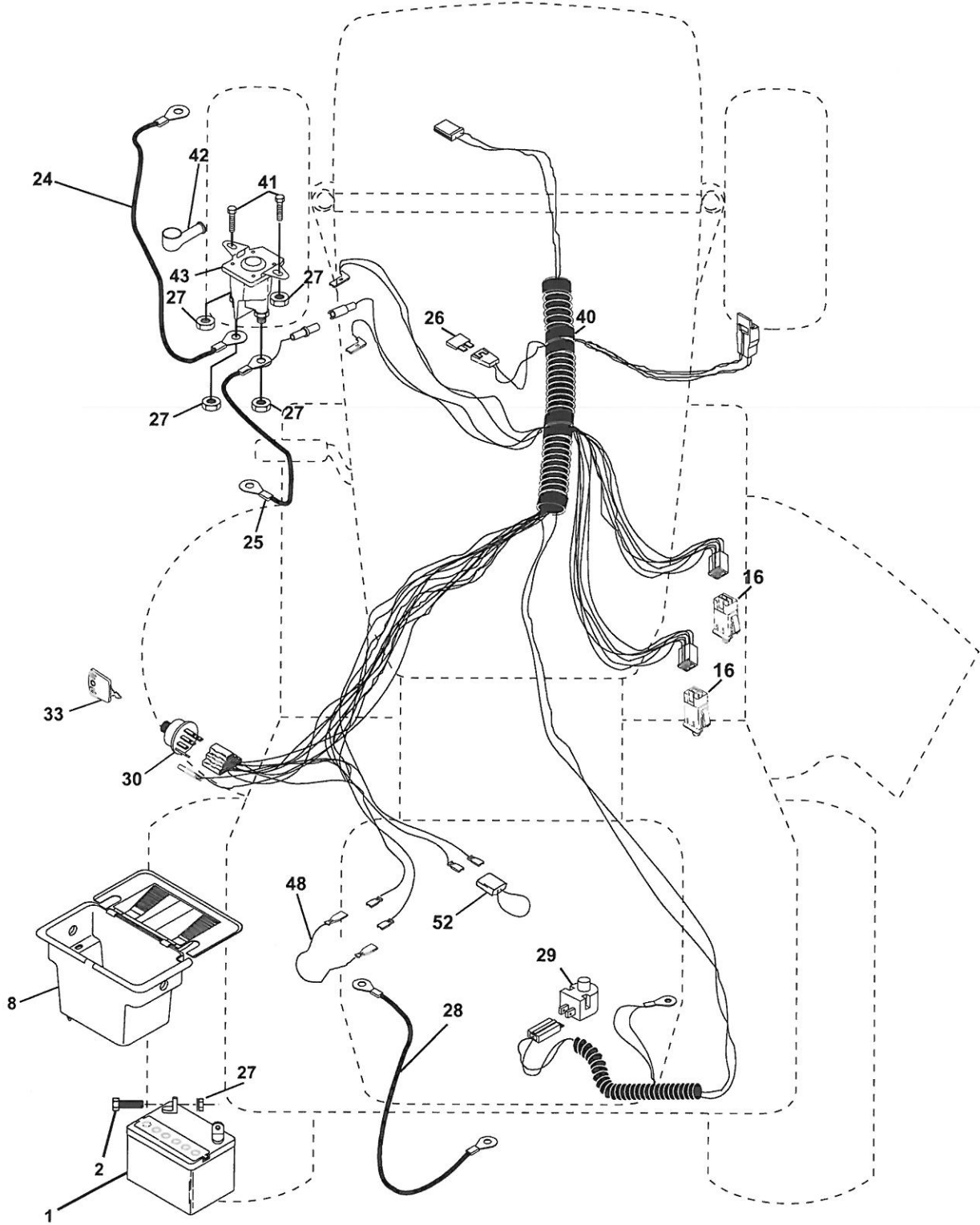

REPAIR PARTS

TRACTOR - - MODEL NUMBER RELTS3611A

ELECTRICAL

KEY NO.	PART NO.	DESCRIPTION
1	144925	Battery 12 Volt 25 Amp
2	74760412	Bolt Hex Hd 1/4-20unc X 3/4
8	156417	Case Battery
16	153664	Switch Interlock Push-In
24	4799J	Cable Starter 6 Ga 11"red
25	146147	Cable Battery 6 Ga red W/ 16" Wire
26	175158	Fuse 20 AMP
27	73510400	Nut, Keps Hex 1/4-20 UNC
28	4207J	Cable Ground 6 Ga 12" black
29	121305X	Switch Plunger Nc Gray
30	175567	Switch, Ignition
33	140401	Key Ign
40	175171	Harness Ign
41	71110408	Bolt Blk Fin Hex 1/4-20 x 1/2
42	131563	Cover Terminal Red
43	175141	Solenoid
48	140844	Adapter Ammeter Rectangular
52	141940	Protection Wire Loop

NOTE: All component dimensions give in U.S. inches
1 inch = 25.4 mm.

REPAIR PARTS

TRACTOR - - MODEL NUMBER RELTS3611A

CHASSIS AND ENCLOSURES

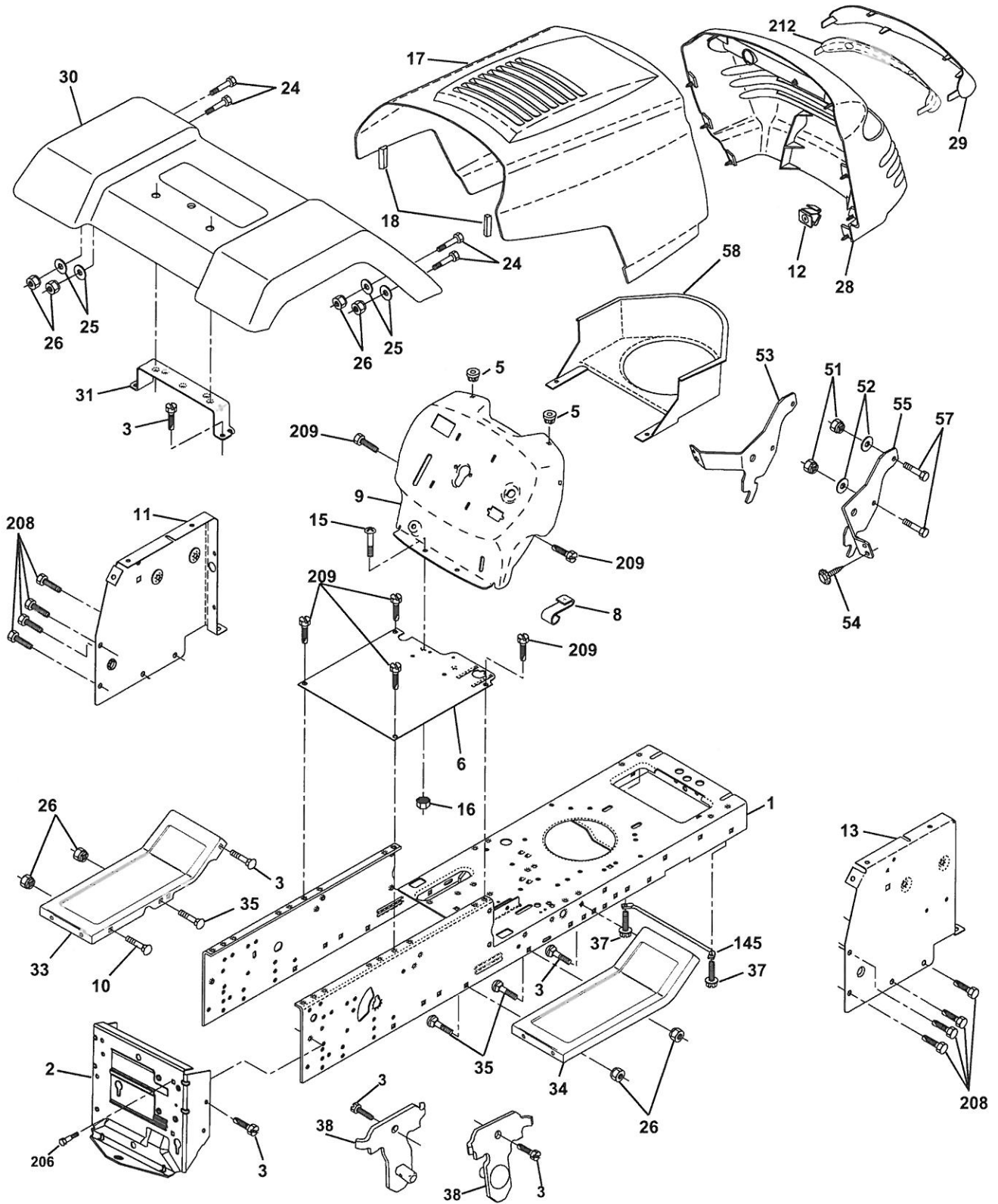

REPAIR PARTS

TRACTOR - - MODEL NUMBER RELTS3611A

CHASSIS AND ENCLOSURES

KEY NO.	PART NO.	DESCRIPTION
1	169831	Chassis
2	169061	Drawbar
3	17060612	Screw 3/8-16 x 3/4
5	155272	Bumper Hood/Dash
6	155924	Saddle
8	155138	Clip, Retainer Slide-On
9	168347X011	Dash
10	72140608	Bolt, Carriage 3/8-16 x 1
11	155927	Dashboard, panel LH
12	145660	Clip Tinnerman Grille P/L
13	172107X010	Dashboard, panel RH
15	74180512	Machine screw 5/16-18 unc x 3/4
16	73510500	Nut, Keps 5/16-18 Unc
17	159639X505	Hood Pnt Stl P/L w/Trim 505
18	126938X	Bumper Hood
24	74780616	Bolt, Hex Head, Fin. 3/8-16 x 1 Grade 5
25	19131312	Washer 13/32 x 13/16 x12 Gauge
26	73800600	Nut Lock Hex w/Ins. 3/8-16 Unc
28	177051	Grille/Lens Asm.
29	140273X428	Lens
30	169465X505	Fender
31	136619	Fender Bracket
33	105476X505	Footrest, LH
34	105475X505	Footrest, RH
35	72110606	Bolt 3/8-16 X 3/4
37	17490508	Screw Thdrol 5/16-18 x 1/2
38	169834	Bracket Asm. Pivot Mower Rear
51	73800400	Nut Lock, w/Insert 14/20 UNC
52	19091416	Washer 9/32 x 7/8 x 16 Ga.
53	144697	Bracket Grille
54	161464	Screw Hex WsHd 8-18 x 7/8
55	144696	Bracket Grille RH
57	74780412	Bolt FinHex 1/4-20 UNC x .75
58	150127	Duct Air Engine P/L LT
145	156524	Rod Pivot Chassis/Hood
206	170165	Bolt Shoulder 5/16-18 TT
208	17670608	Screw Thdrol 3/8-16 x 1/2
209	17000612	Screw Hexwsh Thdr 3/8-16 x 3/4
212	156229	Insert Lens Reflect
--	5479J	Button Plug

NOTE: All component dimensions given in U.S. inches
1 inch = 25.4 mm

REPAIR PARTS

TRACTOR - - MODEL NUMBER RELTS3611A

DRIVE

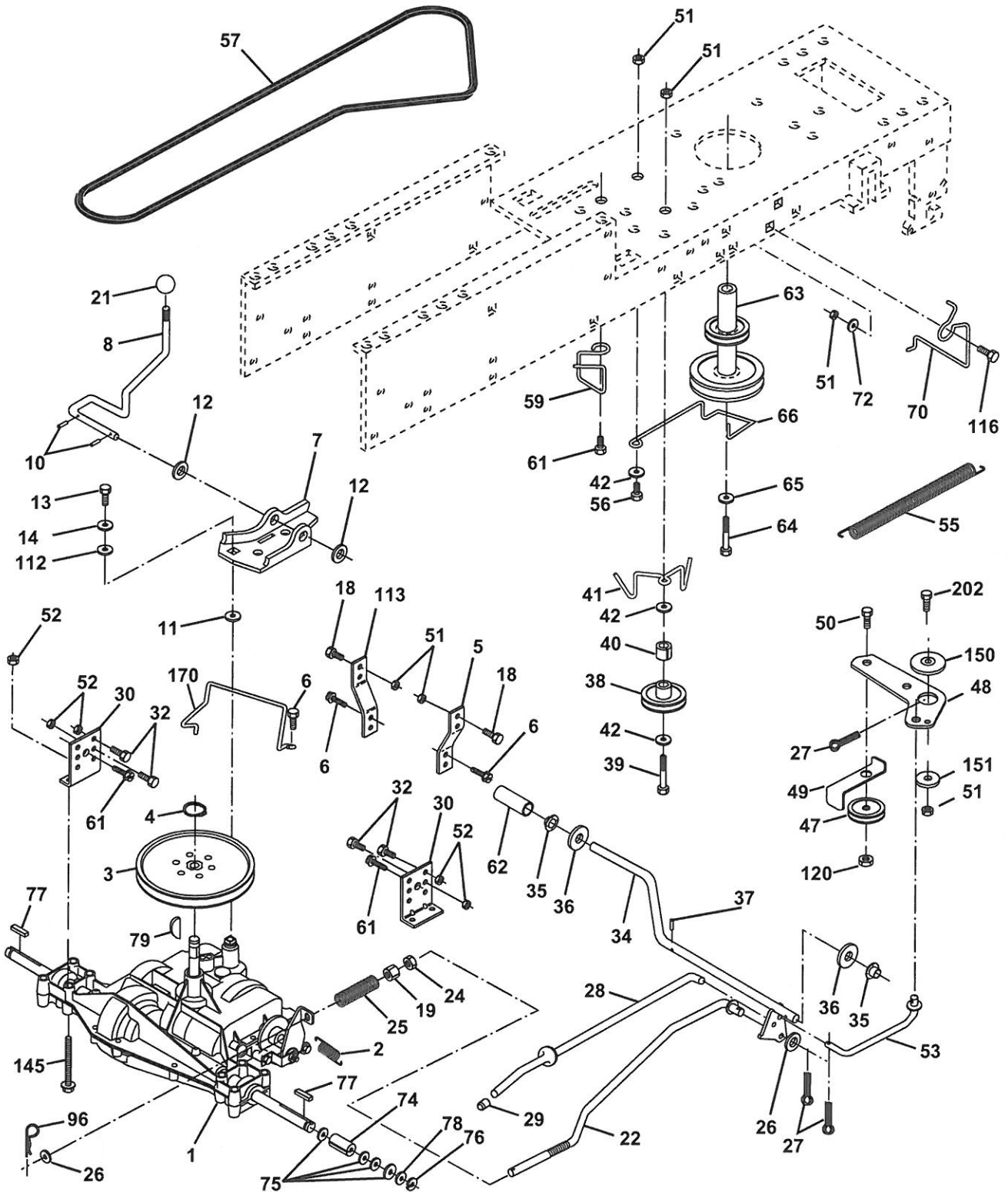

REPAIR PARTS

TRACTOR - - MODEL NUMBER RELTS3611A

DRIVE

KEY NO.	PART NO.	DESCRIPTION	KEY NO.	PART NO.	DESCRIPTION
1	-----	Transaxle Peerless, Model 204-506B (Order parts from transaxle manufacturer)	48	154407	Bellcrank Asm Clutch Retainer, Belt
2	146682	Spring, Brake Return	49	123205X	Bolt, Hex 3/8-16 x 1-1/2
3	123666X	Pulley, Transaxle	50	74760624	Nut, Crownlock 3/8-16
4	12000028	Ring, Retainer	51	73680600	Nut, Crownlock 5/16-18
5	121520X	Strap, Torque	52	105710X	Link, Clutch
6	17060512	Screw, 5/16-18 x 3/4 SMGML	53	105709X	Spring, Return, Clutch
7	162240	Bracket, T/A, Saddle Shift	54	74760620	Bolt, Fin, Hex 3/8-16unc x 1-1/2
8	131679	Rod, Shifter	55	130801	V-Belt, Drive
10	76020416	Pin, Cotter 1/8 x 1	56	169691	Keeper Belt Center Span
11	105701X	Washer, Shift Plate	57	17060612	Screw, 3/8-16 x 3/4 SMGML
12	19151216	Washer 15/32 x 3/4 x 16	58	8156H	Cover, Foot Pedal
13	74550412	Bolt 1/4-28 UNF Gr. 8 w/Patch	59	140186	Pulley, Engine
14	10040400	Washer Lock	60	71170764	Bolt, Hex 7/16-20 x 4 Gr. 5
18	74780616	Bolt, Fin Hex 3/8-16 Unc x 1 Gr. 5	61	10040700	Washer, Lock Hvy Hlcl Spr 7/16
19	73800600	Locknut 3/8-16	62	154778	Keeper, Belt Engine F-Proof
21	106933X	Knob	63	134683	Guide Belt Mower Drive RH
22	130804	Rod, Brake	64	19132012	Washer 13/32 x 1-1/4 x 12 Ga.
24	73350600	Nut, Hex Jam 3/8-16	65	137057	Spacer, Split
25	106888X	Spring, Rod, Brake	66	121749X	Washer 25/32 x 1-1/4 x 16 Ga.
26	19131316	Washer 13/32 x 13/16 x 16 Gauge	67	12000001	E-Ring
27	76020412	Pin, Cotter 1/8 x 3/4	68	123583X	Key Square
28	145204	Rod, Brake, Park	69	121748X	Washer 25/32 x 1-5/8 x 16 Ga.
29	71673	Cap, Plunger	70	2228M	Key Woodruff #9 3/16 x 3/4
30	174973	Bracket, Transaxle	71	4497H	Retainer Spring 1" Ziinc/Cad
32	74760512	Bolt Hex Hd 5/16-18 UNC x 3/4	72	19091210	Washer 9/32 x 3/4 x 10 Ga.
34	155071	Shaft, Foot Pedal	73	127285X	Strap Torque L.H. Lt
35	120183X	Bearing Nylon	74	72110610	Bolt, RdHd Sq Neck 3/8-16 x 1.25
36	19211616	Washer 21/32 x 1 x 16 Gauge	75	73900600	Nut Lock Flg. 3/8-16
37	1572H	Pin, Roll 3/16 x 1	76	74490540	Bolt, Hex Flghd 5/16-18 Gr. 5
38	131494	Idler, Flat	77	165850	Bushing, Bellcrank Grd Dr.
39	74760644	Bolt Fin Hex 3/8-16 Unc x 2-3/4	78	19133210	Washer 13/32 x 2 x 10 Ga.
40	4470J	Spacer	79	173898	Keeper, Belt, Transaxle
41	165838	Keeper, Belt	80	72110612	Bolt Carr Sh 3/8-16 x 1-1/2 Gr. 5
42	19131312	Washer 13/32 x 13/16 x 12 Gauge			
47	127783	Pulley, Idler			

NOTE: All component dimensions given in U.S. inches
1 inch = 25.4 mm

REPAIR PARTS

TRACTOR - - MODEL NUMBER RELTS3611A

STEERING

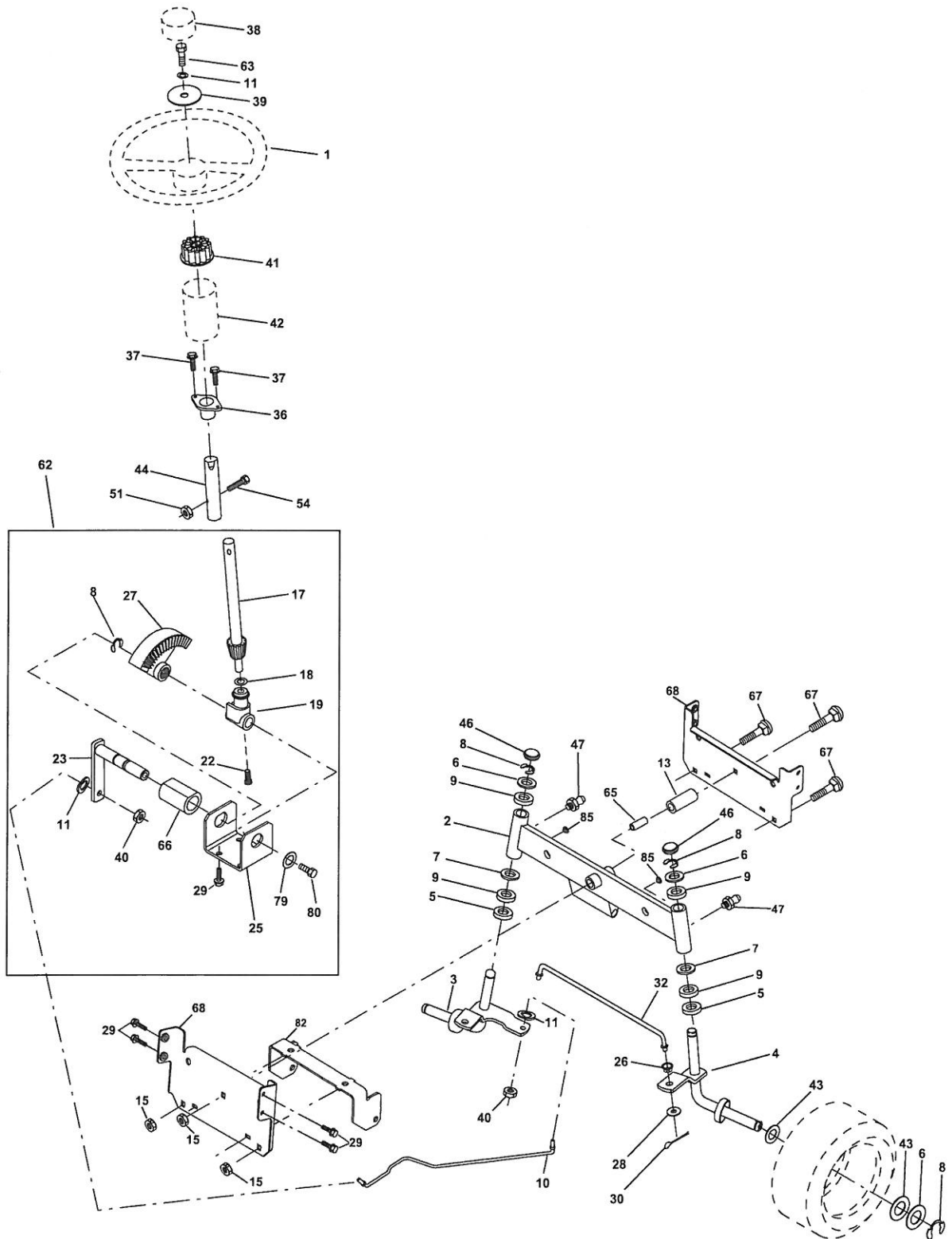

REPAIR PARTS

TRACTOR - - MODEL NUMBER RELTS3611A

STEERING

KEY NO.	PART NO.	DESCRIPTION
1	133741X428	Wheel, Steering
2	154427	Asm. Axle, Rear
3	169840	Asm., Spindle, Lh
4	169839	Asm., Spindle, Rh
5	6266H	Bearing, Thrust, Hardened
6	121748X	Washer 25/32 x 1-5/8 x 16 Ga.
7	19272016	Washer 27/32 x 1-1/4 x 16 Ga.
8	12000029	Ring, Clip
9	3366R	Bearing
10	169832	Link, Drag
11	10040600	Washer, Lock
13	136518	Spacer Brg Axle Front
15	145212	Nut Hex Flange Lock
17	156546	Asm. Shaft, Steering
18	57079	Washer, Thrust .515 x .750 x .033
19	160395	Support, Shaft
22	165857	Screw, Hex Wshhd Torx
23	165851	Shaft, Asm Pitman
25	154406	Bracket, Steering
26	126847X	Bushing, Link, Drag
27	136874	Gear, Sector
28	19131416	Washer 13/32 x 7/8 x 16 Ga.
29	17060612	Screw, 3/8-16 x 3/4
30	76020412	Pin, Cotter
32	130465	Rod, Tie
36	155099	Bushing, Steering
37	152927	Screw
38	133742X428	Insert, Steering
39	19133812	Washer 13/32 x 2-3/8 x 12 Ga.
40	7810H	Nut
41	100711L	Adapter, Steering
42	145054X428	Boot, Shaft Steering Blk
43	121749X	Washer 25/32 x 1-1/4 x 16 Ga.
44	153720	Extension Steering Non-Adjust
46	121232X	Cap, Spindle
47	6855M	Fitting, Grease
51	73800500	Nut Lock Hex w/Ins. 5/16-18 Unc
54	74780520	Bolt Fin Hex 5/16-18 Unc x 1-1/4
62	167902	Kit, Steering Asm, Service
63	74780616	Bolt Fin Hex 3/8-16 Unc x 1 Gr. 5
65	160367	Spacer Brace Axle
66	154404	Bearing Arm Pittman
67	72140618	Bolt Rdhd Sq 3/8-16 Unc x 2-1/4
68	169827	Axle, Brace
79	19132012	Washer 13/32 x 1-1/4 x 12 Ga.
80	74950612	Bolt, Hex Nylon 3/8-16 x 3/4
82	169835	Bracket Susp Chassis Front
85	133835	Fastner Christmas Tree

NOTE: All component dimensions given in U.S. inches
1 inch = 25.4 mm

REPAIR PARTS

TRACTOR - - MODEL NUMBER RELTS3611A

ENGINE

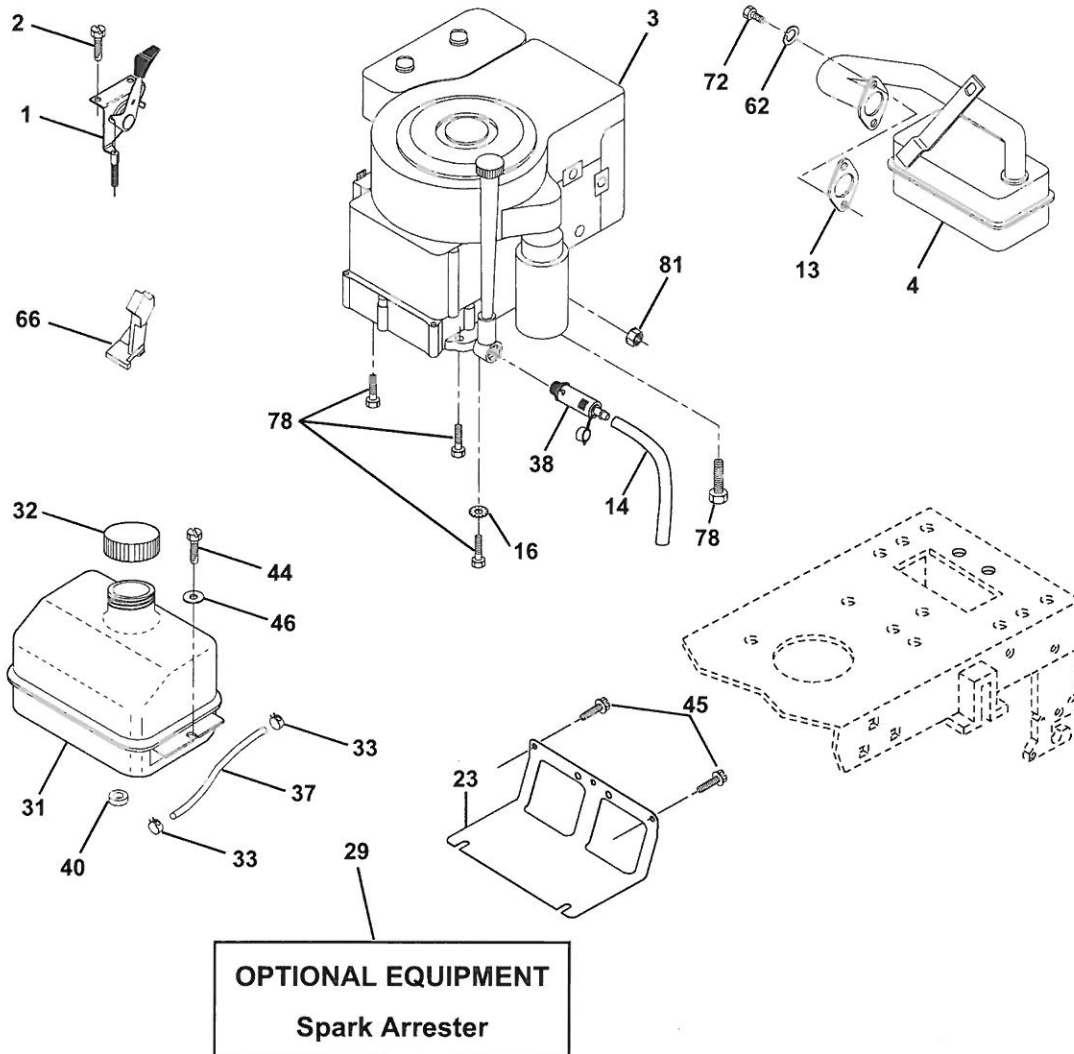

KEY NO.	PART NO.	DESCRIPTION
1	170865	Control Th/ch Flag EEC 20.22
2	17720410	Screw Hex Thd Cut 1/4-20x5/8 T
3	-----	Engine Briggs Model 289707 (Order parts from engine manufacturer)
4	137348	Muffler LT
13	165291	Gasket Eng 1 313 Id Tin Plated
14	148456	Drain Oil Tube Easy
16	11050600	Washer Lock Ext Tooth 3/8
23	169837	Shield Brn/Dbr Guard
29	137180	Kit Spark Arrestor (Flat Scrm)
31	109202X	Tank Fuel Front 2 00
32	140527	Cap Asm Fuel
33	123487X	Clamp Hose Blk

KEY NO.	PART NO.	DESCRIPTION
37	137040	Line Fuel
38	148315	Plug Drain Oil Easy
40	124028X	Bushing Snap Nyl Blk Fuel Line
44	17670412	Screw Hexwsh Thdrol 1/4-20x3/4
45	17000612	Screw Hex Wsh Thdr 3/8-16 x 3/4
46	19091416	Washer 9/32 X 7/8 X 16 Ga
62	10040500	Washer 5/16
66	127951	Stop Throttle 3000 RPM
72	71070512	Screw Hex Hd Cap 5/16-18 x 3/4
78	17060620	Screw 3/8-16x1-1/4
81	73510400	Nut Keps Hex 1/4-20 Unc

NOTE: All component dimensions given in U.S. inches.
1 inch = 25.4 mm.

REPAIR PARTS

TRACTOR - - MODEL NUMBER RELTS3611A

SEAT

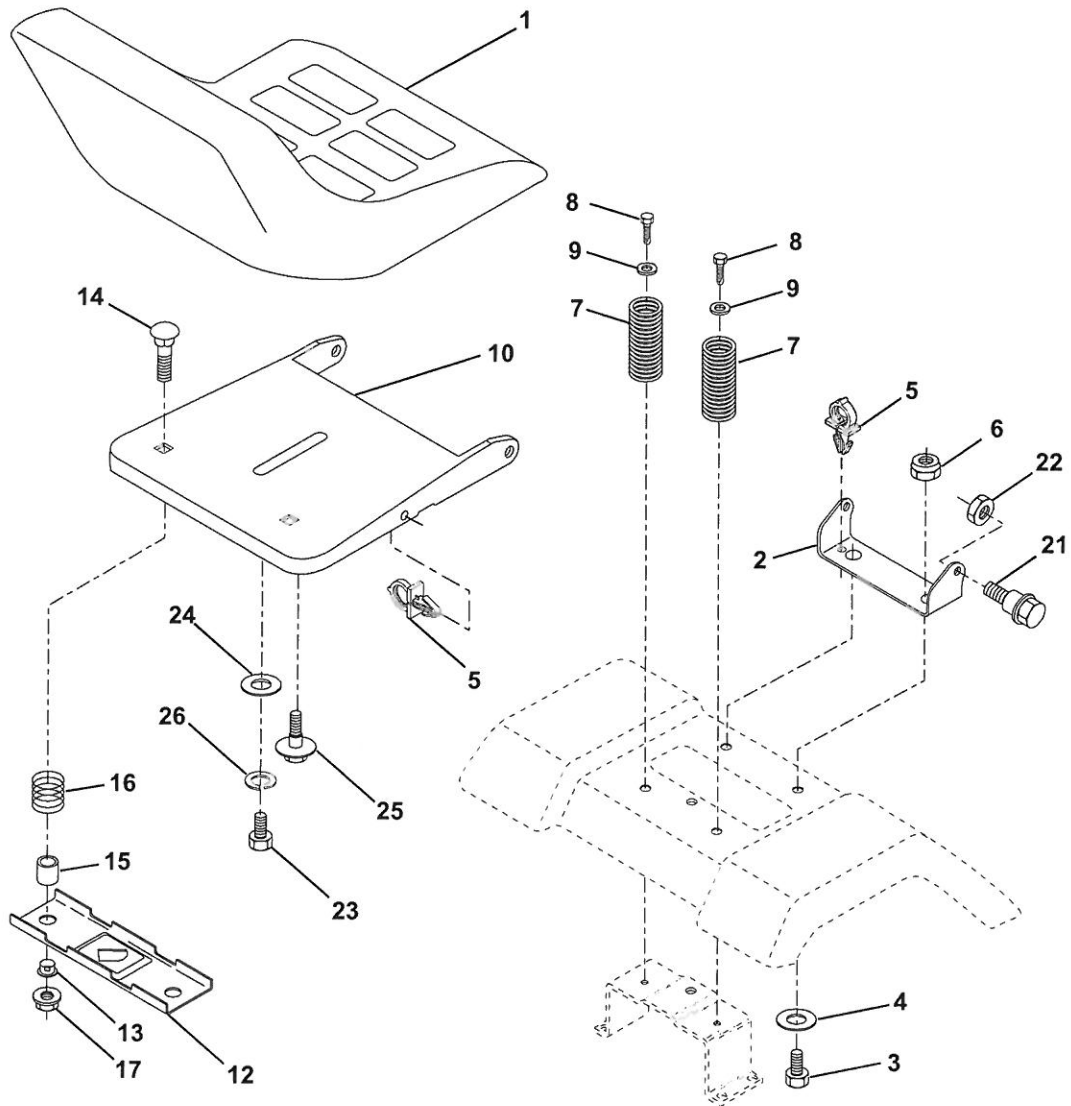

KEY NO.	PART NO.	DESCRIPTION
1	127426X	Seat
2	140551	Bracket, Pivot, Seat
3	71110616	Bolt
4	19131610	Washer 13/32 x 1 x 10 Ga.
5	145006	Clip, Push-in
6	73800600	Nut
7	124181X	Spring, Seat
8	17000616	Screw, Thdrol 3/8-16 x 1-1/2
9	19131614	Washer 13/32 x 1 x 14 Ga.
10	174894	Pan, Asm Seat
12	121246X	Bracket, Mounting, Switch, Seat
13	121248X	Bushing, Nylon

KEY NO.	PART NO.	DESCRIPTION
14	72050412	Nut, Crownlock 1/4-20 x 1-1/2
15	134300	Spacer, Split
16	121250X	Spring
17	123976X	Nut, Lock, Flange 1/4 Gr. 5
21	171852	Bolt, Shoulder 5/16-18 UNC
22	73800500	Nut
23	71110814	Bolt Hex Blk
24	19171912	Washer 17/32 x 1-3/16 x 12 Ga.
25	127018X	Bolt Shoulder 5/16-18 x .62
26	10040800	Washer Lock Hvy Hclc Spr 1/2

NOTE: All component dimensions given in U.S. inches
1 inch = 25.4 mm

REPAIR PARTS

TRACTOR - - MODEL NUMBER RELTS3611A

DECALS

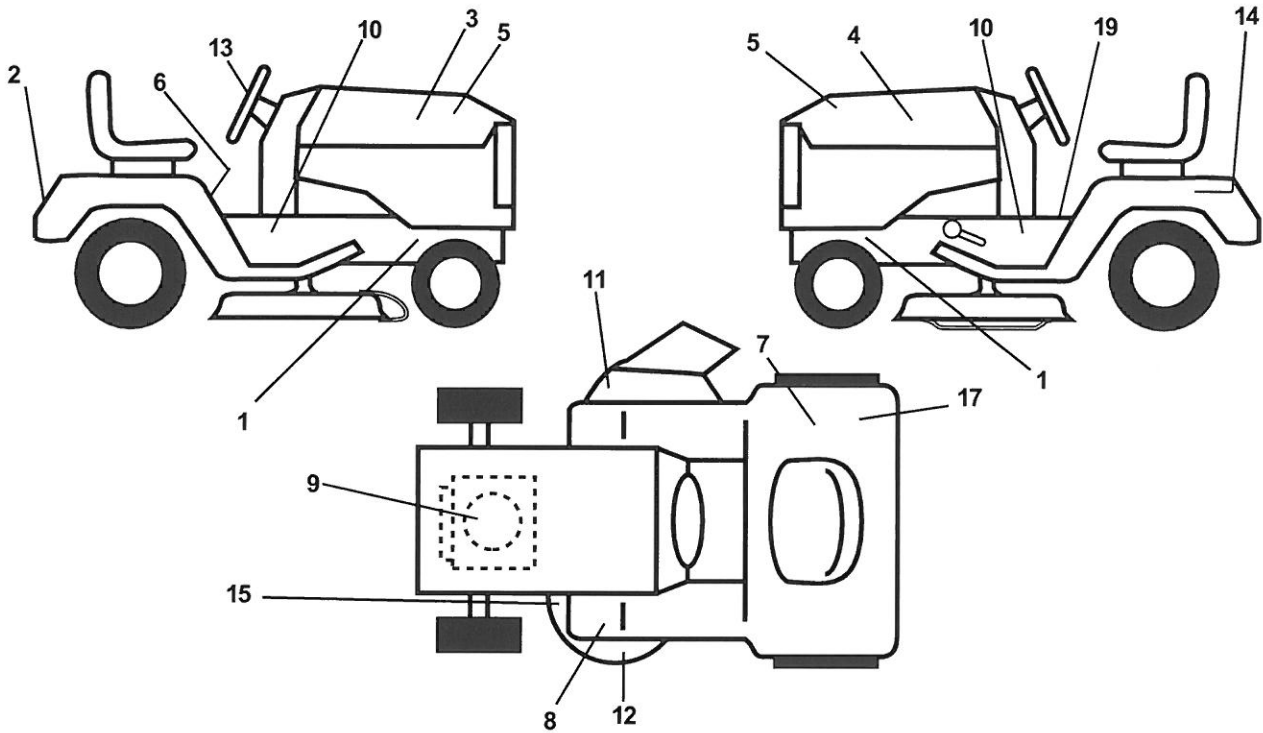

KEY NO.	PART NO.	DESCRIPTION
1	159736	Decal, Chassis Hot Muffler
2	170752	Decal, Fender Logo
3	153266	Decal, Hood Rh
4	153267	Decal, Hood Lh
5	175698	Decal, HP Hood
6	145498	Decal, Read Owner's Manual Syms
7	145437	Decal, Europe Stand CE
8	159737	Decal, Brake/Clutch Symbol LT
9	170843	Decal, HP Engine
10	175697	Decal Chassis
11	145494	Decal, Mower Cutfinger Symbol
12	134999	Decal, Enviro Deck White

KEY NO.	PART NO.	DESCRIPTION
13	127075	Decal Wheel Steering
14	145005	Decal, Battery Dan/Poi P/L Symbols
15	136832	Decal, V-Belt
17	126187X	Decal, 100 DBA
19	140837	Decal, Parking Brake
--	138311	Decal, Handle, Lift, Height Adjust (Lift Handle)
--	162598	Decal, Drawbar Load Limit
--	176902	Manual, Operator's (European)
--	177023	Manual, Repair Parts

TIRES AND WHEELS

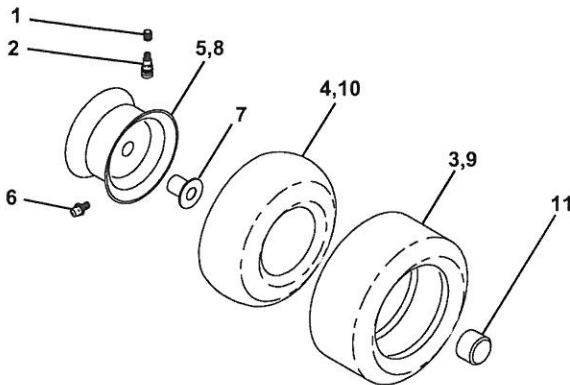

KEY NO.	PART NO.	DESCRIPTION
1	59192	Cap, Valve
2	65139	Stem, Valve
3	124157X	Tire Front
4	59904	Tube, Front (not furnished)
5	106732X427	Rim, Asm. Front
6	278H	Grease Fitting (rear tire only)
7	9040H	Bearing, Flange (front tire only)
8	106108X427	Rim, Asm. Rear
9	123969X	Tire, Rear
10	7152J	Tube, Rear (not furnished)
11	104757X428	Cap, Axle
--	144334	Sealant, Tire (10 oz. Tube)

NOTE: All component dimensions given in U.S. inches
1 inch = 25.4 mm

REPAIR PARTS

TRACTOR - - MODEL NUMBER RELTS3611A

MOWER LIFT

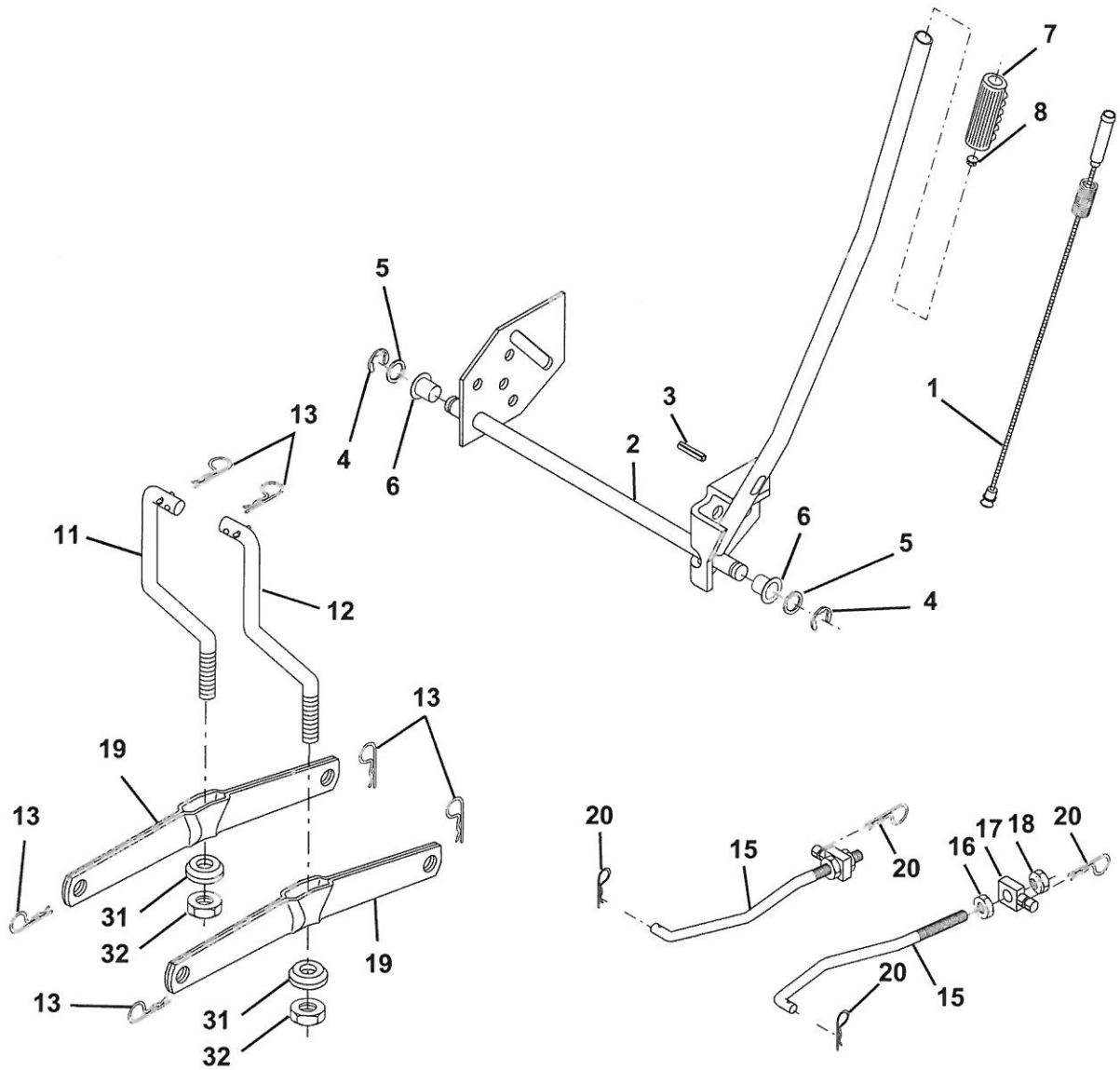

KEY NO.	PART NO.	DESCRIPTION
1	159460	Asm. Inner Wire w/Plunger
2	159471	Asm., Shaft, Lift
3	105767X	Pin, Groove
4	12000002	Ring, E #5133-62
5	19211621	Washer 21/32 x 1 x 21 Ga.
6	120183X	Bearing, Nylon
7	109413X	Grip Handle Bicycle Matte Blk
8	124526X	Button, Plunger
11	139865	Link, Lift, Lh
12	139866	Link, Lift, Rh
13	4939M	Spring, Retainer

KEY NO.	PART NO.	DESCRIPTION
15	173288	Link, Front
16	73350800	Nut, Jam, Hex 1/2-13 Unc
17	130171	Trunnion
18	73800800	Nut Lock w/wsh 1/2-13 Unc
19	139868	Arm, Suspension, Rear
20	163552	Spring, Retainer
31	169865	Bearing, Pvt Lft
32	73540600	Nut Crownlock 3/8-24

NOTE: All component dimensions given in U.S. inches
1 inch = 25.4 mm

REPAIR PARTS

TRACTOR - - MODEL NUMBER RELTS3611A

MOWER DECK

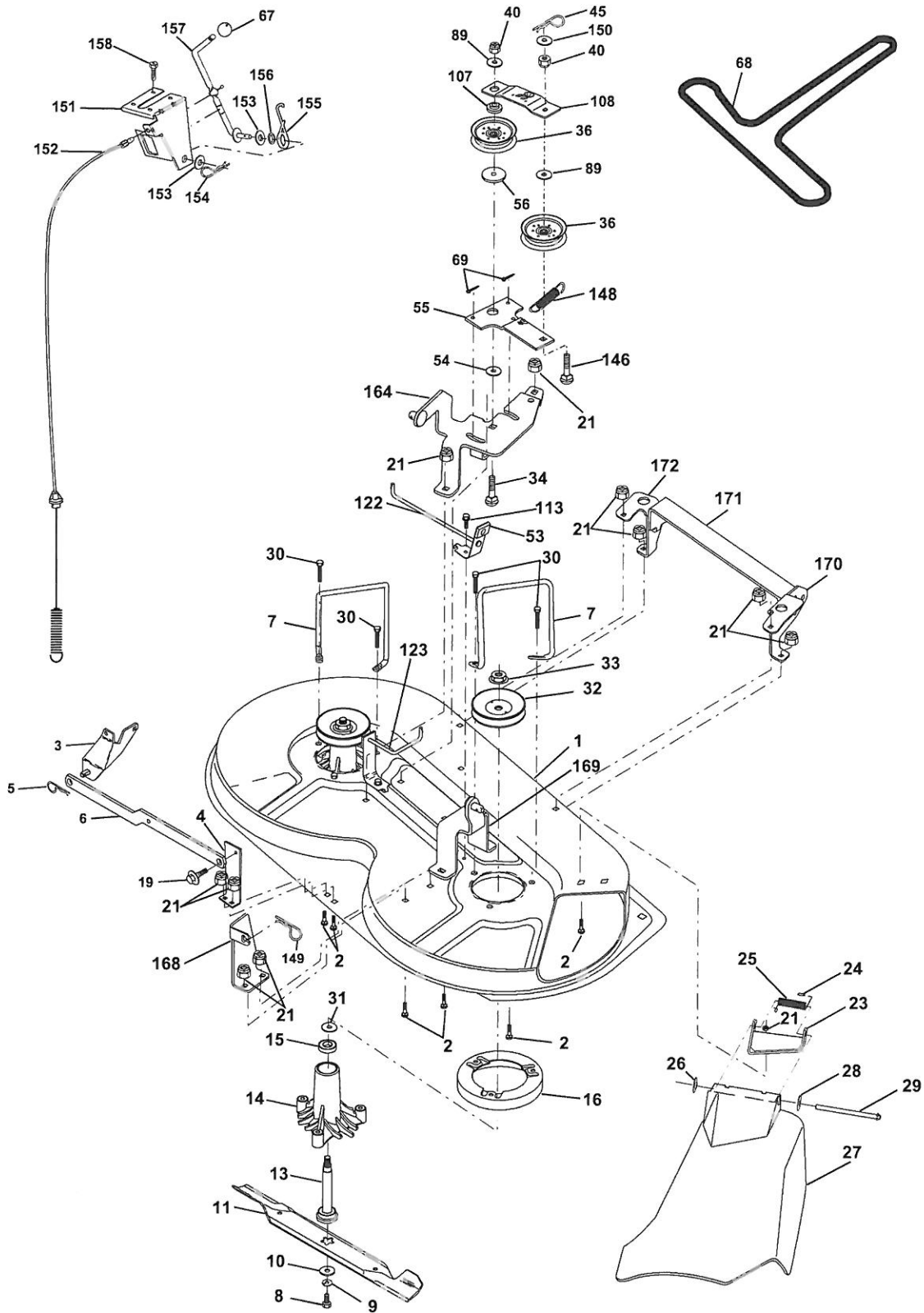

REPAIR PARTS

TRACTOR - - MODEL NUMBER RELTS3611A

MOWER DECK

KEY NO.	PART NO.	DESCRIPTION	KEY NO.	PART NO.	DESCRIPTION
1	174595	Mower Deck Assembly	55	133840	Idler Arm Assembly
2	72140506	Bolt	56	165723	Spacer, Retainer
3	138017	Bracket Assembly, Sway Bar	67	106932X	Knob RD 3/8-16 Plstc Thd
4	175654	Bracket Sway Bar	68	174978	Belt
5	4939M	Retainer Spring	69	76020312	Pin, Cotter 3/32 x 3/4
6	130832	Arm, Suspension, Rear	89	19131612	Washer 13/32 x 1 x 12 Ga
7	140608	Keeper Belt	107	133502	Spacer, Retainer
8	850857	Bolt, Hex 3/8-24 x 1.25 Gr. 8	108	133503	Stiffener, Idler Arm
9	10030600	Washer, Lock Hvy Hlcl 3/8	113	17490508	Screw Thdrol 5/16-18 x 1/2
10	140296	Washer, Hardened	122	174505	Rod, Brake, LH
11	138496	Blade, Mower	123	174504	Rod, Brake, RH
13	137645	Shaft Assembly, Mandrel, Vented	146	165891	Bolt Carriage Idler
14	128774	Housing, Mandrel, Vented	148	169022	Spring Return Idler
15	110485X	Bearing, Ball, Mandrel	149	165898	Retainer Spring Yellow Zinc
16	174493	Stripper, Mower Deck	150	19091216	Washer 9/32 x 3/4 x 16 Ga.
19	132827	Bolt, Shoulder	151	169670	Bracket Clutch
21	73680500	Nut Crownlock 5/16-18	152	176079	Cable Clutch
23	136631	Bracket, Mower Deflector	153	169674	Washer Flat 3/8" Type B
24	105304X	Cap, Sleeve	154	169675	Spring Retainer
25	123713X	Spring, Torsion, Deflector	155	169671	Spring Retention Lever
26	110452X	Nut, Push	156	169672	Spacer
27	175029X428	Shield, Deflector	157	169669	Rod Clutch
28	19111016	Washer 11/32 x 5/8 x 16 Ga.	158	17720410	Screw Hex Thd Cut 1/4-20x5/8
29	121980X	Rod, Hinge	164	174976	Bracket Asm Idler Support
30	157722	Screw Thdrol Washer Head	168	172377	Bracket Deck Cable
31	129963	Washer, Spacer	169	174977	Bracket Asm Suspension
32	153531	Pulley, Mandrel	170	172359	Bracket Suspension RF
33	137266	Nut, Toplock, Flanged	171	165237	Brace Support Susp. Frt
34	72110614	Bolt Rdhd 3/8-16 x 1-3/4	172	172355	Bracket Suspension LF
36	131494	Pulley, Idler, Flat	--	130794	Mandrel Assembly (Includes Key Numbers 12-15, 17-19, 31 and 33)
40	73680600	Nut Crownlock 3/8-16	--	175254	Mower Deck, Complete
45	4497H	Retainer, Spring			
53	130840	Brake Assembly			
54	133943	Washer, Hardened			

NOTE: All component dimensions given in U.S. inches
1 inch = 25.4 mm