

REPAIR PARTS MANUAL
MODEL NO. REB1192 (REB1192C)
Lawn Tractor

Rally

00137

HOW TO USE THIS MANUAL

This manual is designed to provide the customer with a means to identify the parts on his/her tractor when ordering repair parts. The illustrations may or may not represent the actual assemblies; therefore, it is not recommended to use this manual as a guide to assemble or disassemble the tractor. Some hardware and parts are drawn larger in order to more readily identify them.

Each tractor has its own model number.

The model number for your tractor can be found on the fender under the seat.

When ordering parts, always give the following information:

- Product - "Lawn Tractor"
- Model Number - REB1192 (REB1192C)
- Part Number
- Part Description

TABLE OF CONTENTS

SCHEMATIC	3
ELECTRICAL.....	4-5
CHASSIS AND ENCLOSURES.....	6-7
DRIVE.....	8-9
STEERING WHEEL	10-11
SEAT	12
DECALS.....	13
ENGINE.....	14-15
MOWER LIFT	16-17
MOWER DECK	18-19

**TRACTOR - - MODEL NUMBER REB1192 (REB1192C), PRODUCT NO. 964 79 60-00
SCHEMATIC**

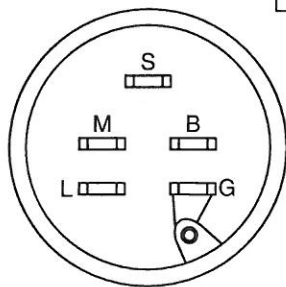
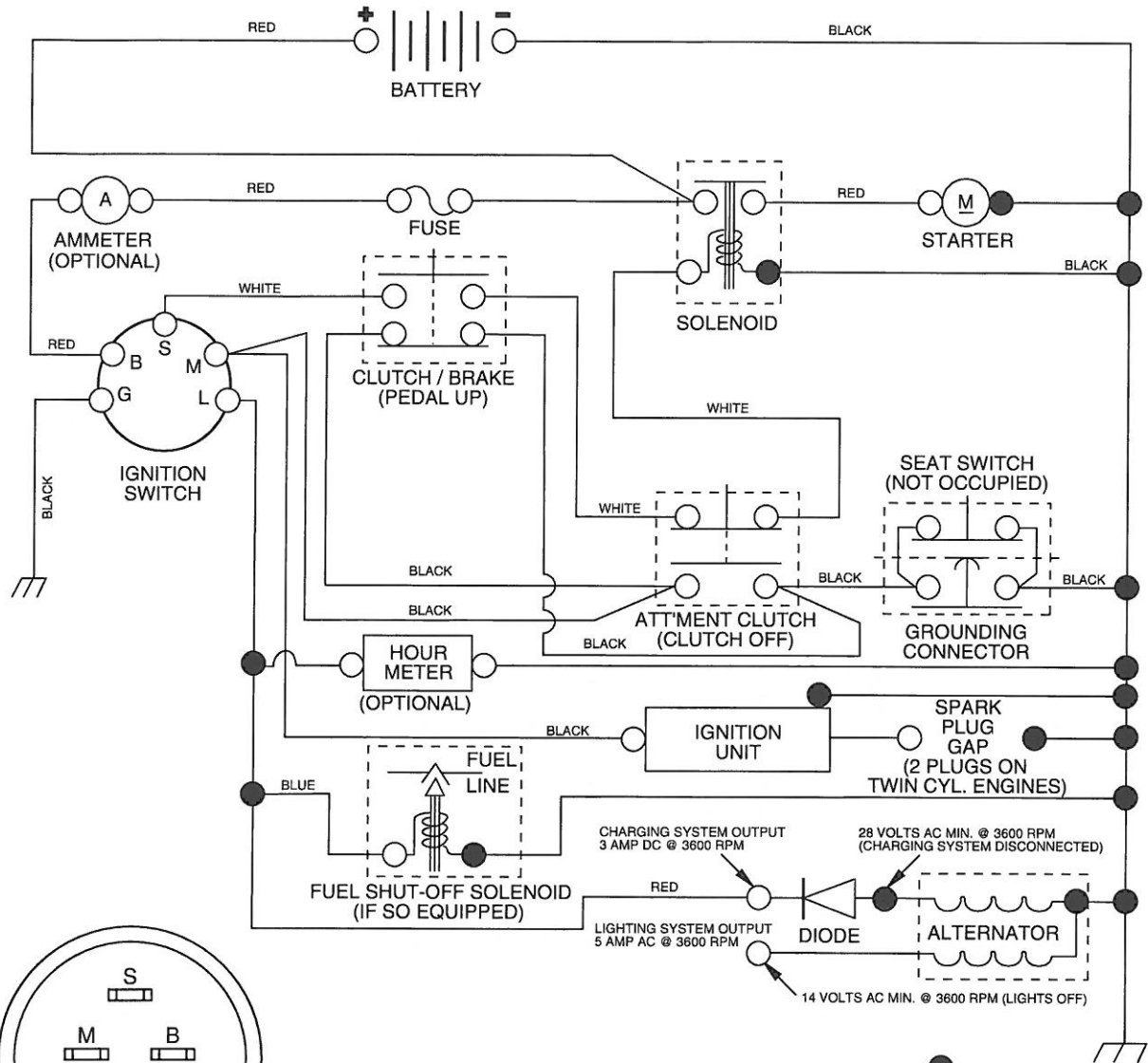

IGNITION SWITCH

POSITION	CIRCUIT
OFF	M + G
ON	B + L
START	B + S + L

WIRING INSULATED CLIPS
NOTE: IF WIRING INSULATED CLIPS WERE REMOVED FOR SERVICING OF UNIT, THEY SHOULD BE REPLACED TO PROPERLY SECURE YOUR WIRING.

● —●
NON-REMOVABLE CONNECTIONS

○ —○
REMOVABLE CONNECTIONS

REPAIR PARTS

TRACTOR - - MODEL NUMBER REB1192 (REB1192C), PRODUCT NO. 964 79 60-00
ELECTRICAL

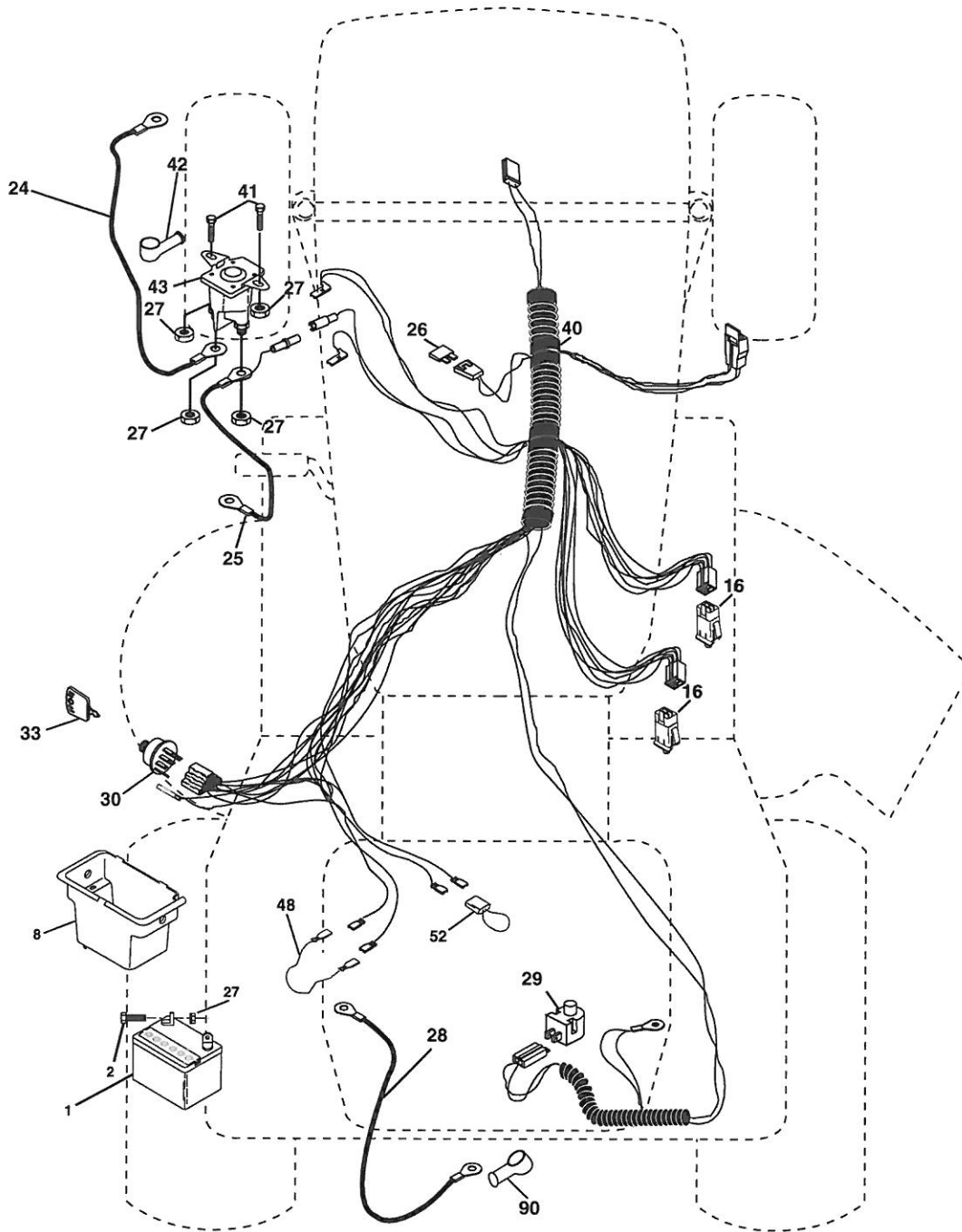

REPAIR PARTS

TRACTOR - - MODEL NUMBER REB1192 (REB1192C), PRODUCT NO. 964 79 60-00
ELECTRICAL

KEY NO.	PART NO.	DESCRIPTION
1	532 16 34-65	Battery
2	874 76 04-12	Bolt Hex Hd 1/4-20 unc x 3/4
8	532 17 66-89	Box Battery Fender
16	532 17 61-38	Switch Interlock
24	532 12 47-80	Cable Battery 6 Ga. 11" Red
25	532 14 61-47	Cable Battery 6 Ga. Red w/16 wir
26	532 17 51-58	Fuse
27	873 51 04-00	Nut Keps Hex 1/4-20 unc
28	532 12 47-73	Cable Ground 6 Ga. 12" black
29	532 12 13-05	Switch Plunger Nc Gray
30	532 17 55-67	Switch Ign
33	532 14 04-01	Key
40	532 17 97-30	Harness Ing
41	871 11 04-08	Bolt Blk Fin Hex 1/4 - 20 x 1/2
42	532 13 15-63	Cover Terminal Red
43	532 17 88-61	Solenoid
48	532 14 08-44	Adapter Ammeter Rectangular
52	532 14 19-40	Protection Wire Loop
90	532 18 04-49	Cover Terminal Battery

NOTE: All component dimensions given in U.S. inches.
1 inch = 25.4 mm.

REPAIR PARTS

TRACTOR - - MODEL NUMBER REB1192 (REB1192C), PRODUCT NO. 964 79 60-00
CHASSIS

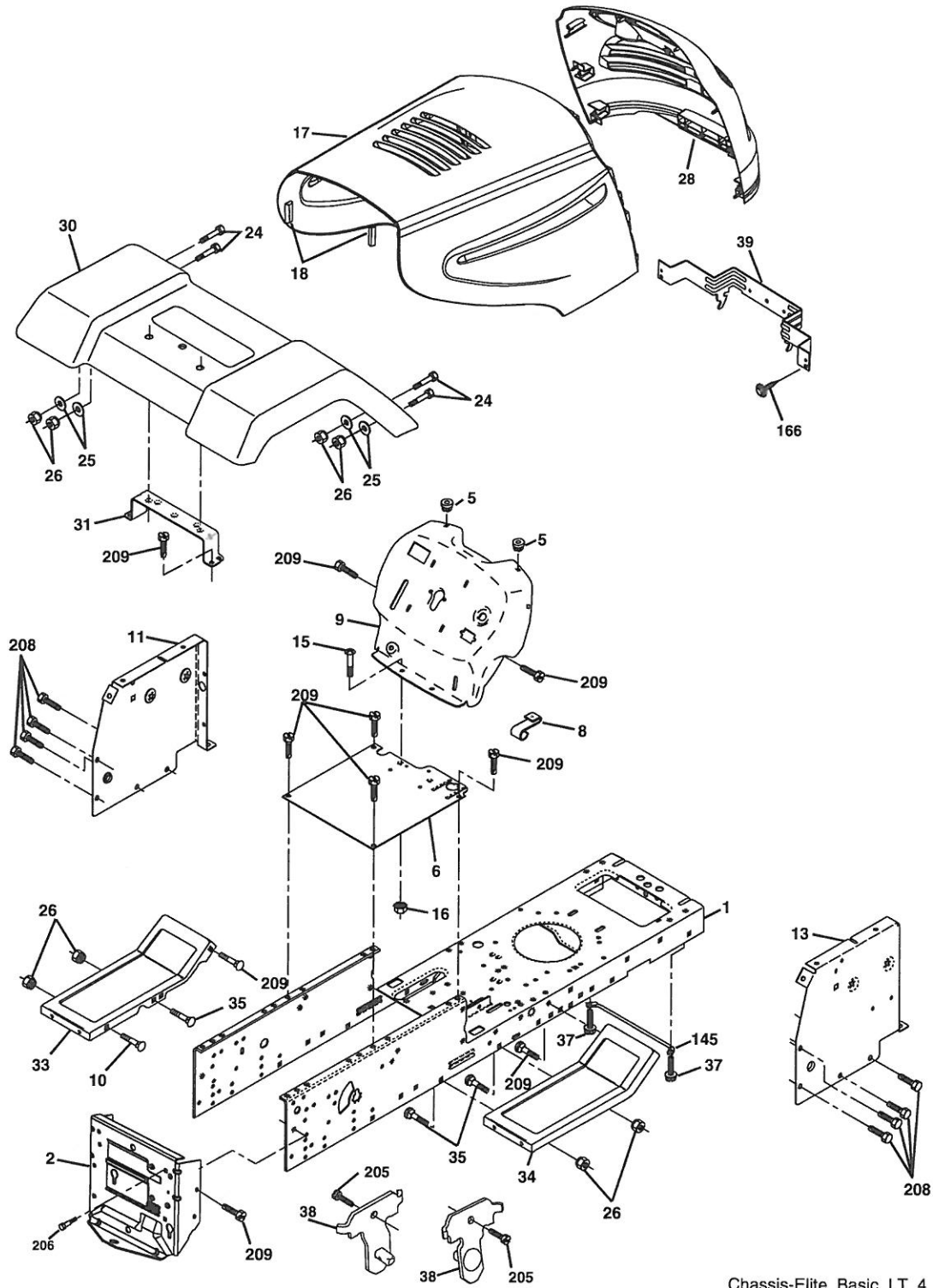

Chassis-Elite_Basic_LT_4

REPAIR PARTS

TRACTOR - - MODEL NUMBER REB1192 (REB1192C), PRODUCT NO. 964 79 60-00
CHASSIS

KEY NO.	PART NO.	DESCRIPTION
1	532 17 46-20	Chassis
2	532 17 65-54	Drawbar
5	532 15 52-72	BumperHood/Dash
6	532 18 12-71	Saddle
8	532 15 51-38	Clip, Retainer Slide-On
9	532 19 06-94	Dash
10	872 14 06-08	Bolt, Carriage 3/8-16 x 1
11	532 17 49-96	Dashboard, Panel LH
13	532 18 69-52	Dashboard, Panel RH
15	874 18 05-12	Machine screw 5/16-18 unc x 3/4
16	873 51 05-00	Nut, Keps 5/16-18 unc
17	532 18 67-07	Hood Pnt
18	532 18 49-21	BumperHood
24	874 78 06-16	Bolt, Hex Head, Fin. 3/8-16 x 1 Gr. 5
25	819 13 13-12	Washer 13/32 x 13/16 x 12 Ga.
26	873 80 06-00	Nut Lock Hex w/Ins. 3/8-16 unc
28	532 18 67-18	Grille
30	532 18 25-35	Fender
31	532 13 66-19	Fender Bracket
33	532 18 11-93	Footrest, LH
34	532 18 11-94	Footrest, RH
35	872 11 06-06	Bolt 3/8-16 x 3/4
37	817 49 05-08	Screw Thdrol 5/16-18 x 1/2
38	532 17 57-10	Bracket Asm. Pivot Mower Rear
39	532 17 47-14	Bracket Pivot
145	532 15 65-24	Rod Pivot Chassis/Hood
166	532 19 16-11	Screw 10 x 3/4 Single Lead-Hex
205	817 49 06-08	Screw Thdrol 3/8-16 x 1/2
206	532 17 01-65	Bolt Shoulder 5/16-18 TT
208	817 67 06-08	Screw Thdrol 3/8-16 x 1/2
209	817 00 06-12	Screw Hexwsh Thdr 3/8-16 x 3/4
--	532 00 54-79	Button Plug

NOTE: All component dimensions given in U.S. inches.
1 inch = 25.4 mm.

REPAIR PARTS

TRACTOR - - MODEL NUMBER REB1192 (REB1192C), PRODUCT NO. 964 79 60-00
DRIVE

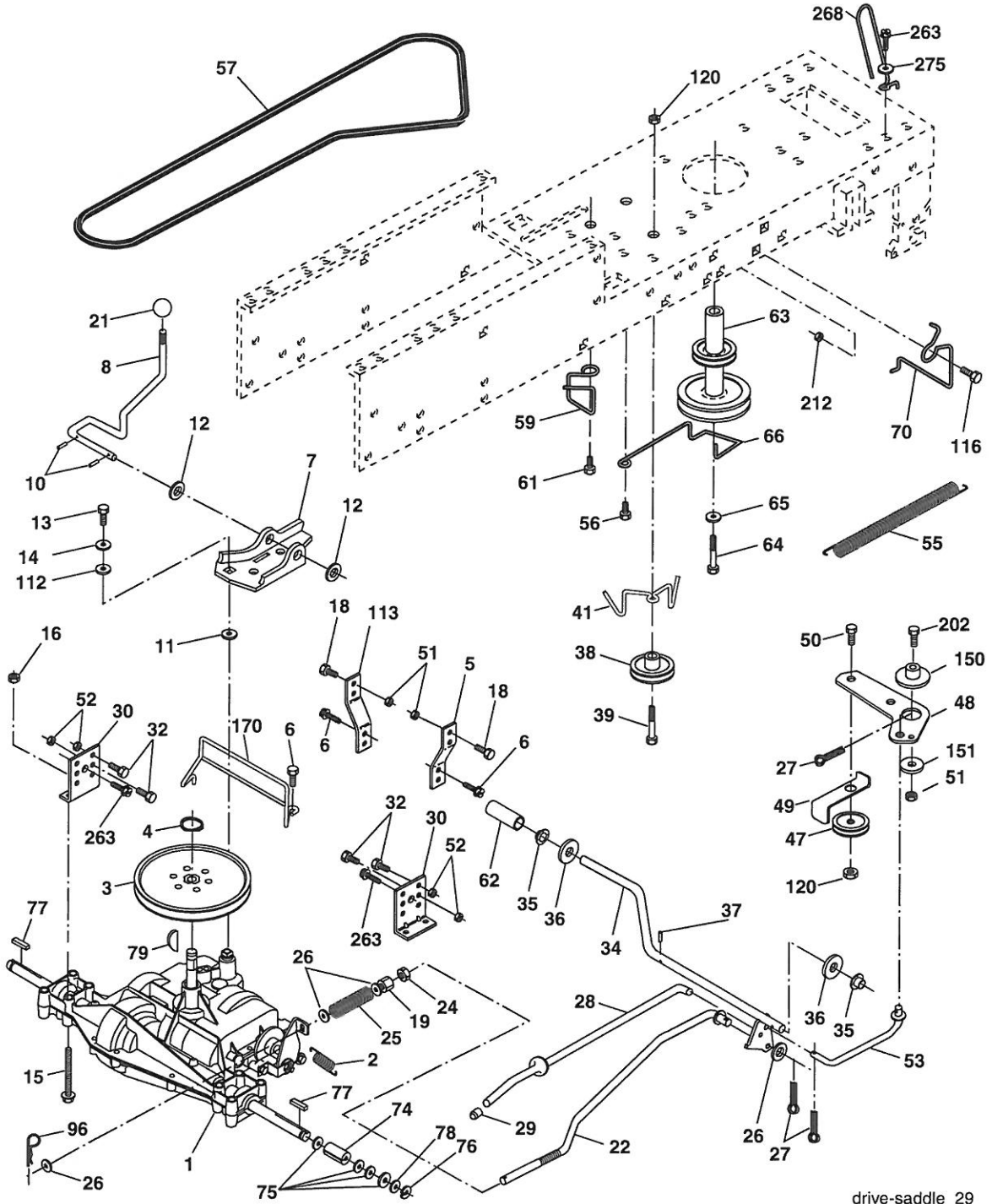

drive-saddle_29

REPAIR PARTS

**TRACTOR - - MODEL NUMBER REB1192 (REB1192C), PRODUCT NO. 964 79 60-00
DRIVE**

KEY NO.	PART NO.	DESCRIPTION	KEY NO.	PART NO.	DESCRIPTION
1	-----	Transaxle, Peerless, Model 204-506B (Order parts from transaxle manufacturer)	48	532 15 44-07	Bellcrank Asm Clutch
2	532 14 66-82	Spring, Brake Return	49	532 12 32-05	Retainer, Belt
3	532 12 36-66	Pulley, Transaxle	50	872 11 06-12	Bolt, 3/8-16 x 1-1/2 Gr. 5
4	812 00 00-28	Ring, Retainer	51	873 68 06-00	Nut, Crownlock 3/8-16
5	532 12 15-20	Strap, Torque	52	873 68 05-00	Nut, Crownlock 5/16-18
6	817 00 05-12	Screw, 5/16-18 x 3/4 SMGML	53	532 10 57-10	Link, Clutch
7	532 16 22-40	Bracket, T/A, Saddle Shift	55	532 10 57-09	Spring, Return, Clutch
8	532 13 16-79	Rod, Shifter	56	817 06 06-20	Screw 3/8-16 x 1-1/4
10	876 02 04-16	Pin, Cotter 1/8 x 1	57	532 13 08-01	V-Belt, Drive
11	532 10 57-01	Washer, Shift Plate	59	532 16 96-91	Keeper Belt Center Span
12	819 15 12-16	Washer 15/32 x 3/4 x 16	61	817 12 06-14	Screw 3/8-16 x .875
13	874 55 04-12	Bolt 1/4-28 unf Gr. 8 w/Patch	62	532 12 48-72	Cover, Foot Pedal
14	810 04 04-00	Washer Lock	63	532 18 02-19	Pulley, Engine
15	874 49 05-44	Bolt, Hex Flghd 5/16-18 Gr. 5	64	532 17 39-37	Bolt, Hex 7/16-20 x 4 Gr. 5
16	873 80 05-00	Nut lock 5/16-18	65	810 04 07-00	Washer, Lock Hvy Hlcl Spr 7/16
18	874 78 06-16	Bolt, Fin Hex 3/8-16 unc x 1 Gr. 5	66	532 15 47-78	Keeper, Belt Engine F-Proof
19	873 80 06-00	Locknut 3/8-16	70	532 18 02-18	Guide Belt Mower Drive RH
21	532 10 69-33	Knob	74	532 13 70-57	Spacer, Split
22	532 13 08-04	Rod, Brake	75	532 12 17-49	Washer 25/32 x 1-1/4 x 16 Ga.
24	873 35 06-00	Nut, Hex Jam 3/8-16	76	812 00 00-01	E-Ring
25	532 10 68-88	Spring, Rod, Brake	77	532 12 35-83	Key Square
26	819 13 13-16	Washer 13/32 x 13/16 x 16 Ga.	78	532 12 17-48	Washer 25/32 x 1-5/8 x 16 Ga.
27	876 02 04-12	Pin, Cotter 1/8 x 3/4	79	532 12 50-96	Key Woodruff #9 3/16 x 3/4
28	532 17 57-65	Rod, Brake, Park	96	532 12 47-80	Retainer Spring 1" Ziinc/Cad
29	532 07 16-73	Cap, Plunger	112	819 09 12-10	Washer 9/32 x 3/4 x 10 Ga.
30	532 17 49-73	Bracket, Transaxle, L.H.	113	532 12 72-85	Strap Torque L.H. Lt
32	874 76 05-12	Bolt Hex Hd 5/16-18 unc x 3/4	116	872 14 06-08	Bolt RDHD SQNK 3/8-16 unc x 1
34	532 17 55-78	Shaft, Foot Pedal	120	873 90 06-00	Nut Lock Flg. 3/8-16 unc
35	532 12 01-83	Bearing Nylon	150	532 17 54-56	SpacerRetainer
36	819 21 16-16	Washer 21/32 x 1 x 16 Ga.	151	819 13 32-10	Washer 13/32 x 2 x 10 Ga.
37	532 12 49-63	Pin, Roll 3/16 x 1	170	532 18 74-14	Keeper, Belt, Transaxle
38	532 17 91-14	Pulley Idler	202	872 11 06-14	Bolt Carr Sh 3/8-16 x 1-3/4 Gr. 5
39	872 11 06-22	Bolt RDHD 3/8-16 unc x 2-3/4 Gr. 5	212	532 14 52-12	Nut Hex Flange Lock
41	532 17 55-56	Keeper, Belt	263	817 00 06-12	Screw 3/8-16 x 3/4
47	532 12 77-83	Pulley, Idler	268	532 18 24-02	Guard Muffler
			275	819 13 16-14	Washer 13/32 x 1 x 14 Ga.

NOTE: All component dimensions given in U.S. inches
1 inch = 25.4 mm

REPAIR PARTS

TRACTOR - - MODEL NUMBER REB1192 (REB1192C), PRODUCT NO. 964 79 60-00
STEERING ASSEMBLY

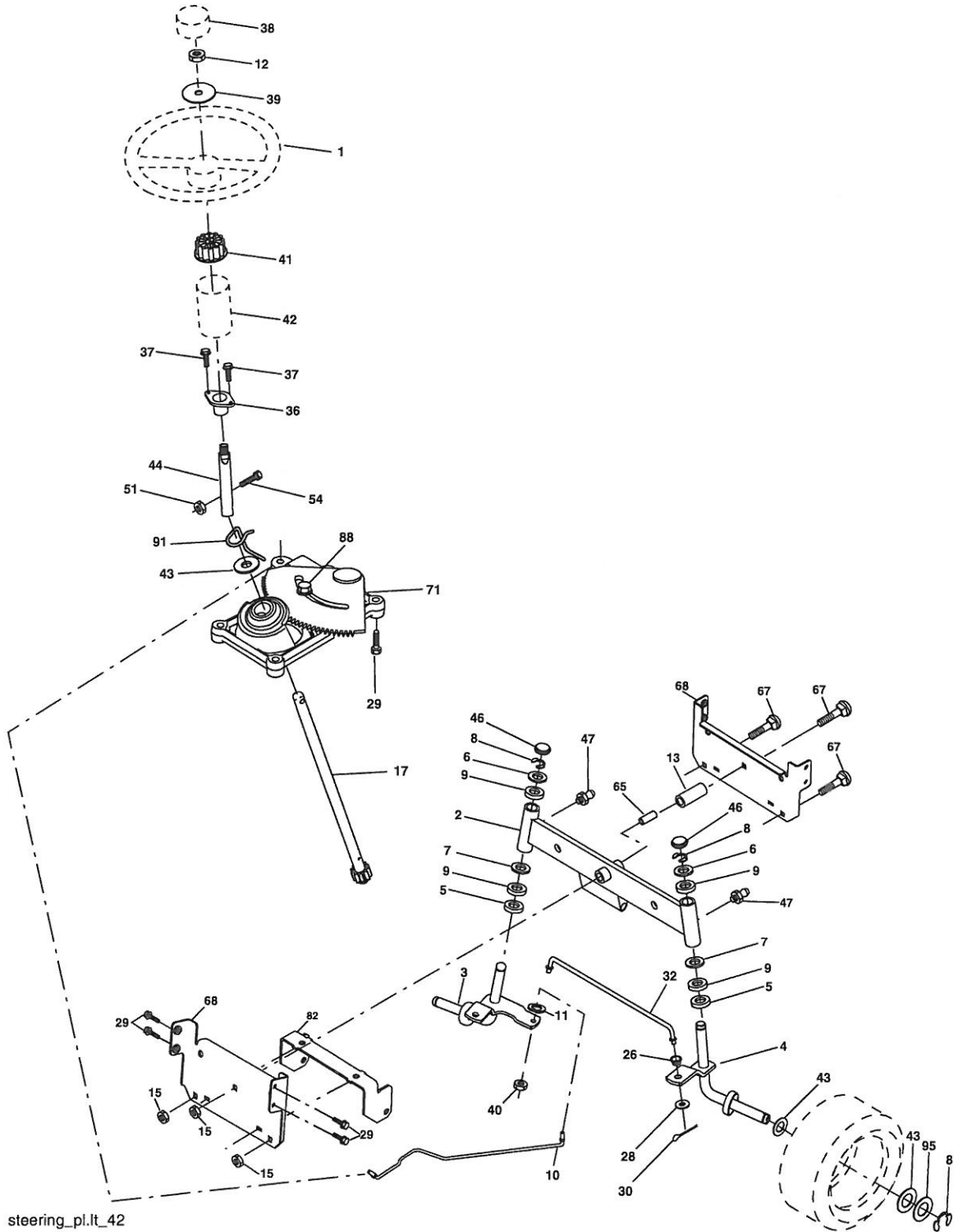

REPAIR PARTS

TRACTOR - - MODEL NUMBER REB1192 (REB1192C), PRODUCT NO. 964 79 60-00 STEERING ASSEMBLY

KEY NO.	PART NO.	DESCRIPTION
1	532 17 59-04	Wheel Steering AYP P/L Black
2	532 17 51-31	Axle Asm
3	532 16 98-40	Spindle Asm LH
4	532 16 98-39	Spindle Asm RH
5	532 12 49-31	Bearing Race Thrust Harden
6	532 12 17-48	Washer 25/32 x 1-5/8 x 16 Ga.
7	819 27 20-16	Washer 27/32 x 1-1/4 x 16 Ga.
8	812 00 00-29	Ring Klip #t5304-75
9	532 12 49-37	Bearing Col Strg Blk
10	532 17 51-21	Link Drag
11	810 04 06-00	Washer Lock Hvy Hlcl Spr 3/8
12	873 94 08-00	Nut Hex Jam Toplock 1/2-20 unf
13	532 13 65-18	Spacer Brace Axle
15	532 14 52-12	Nut Hexflange Lock
17	532 18 06-41	Shaft Asm Strg
26	532 12 68-47	Bushing Link Drag Blk LR
28	819 13 14-16	Washer 13/32 x 7/8 x 16 Ga.
29	817 00 06-12	Screw 3/8-16 x .75
30	876 02 04-12	Pin Cotter 1/8 x 3/4 Cad
32	532 13 04-65	Rod Tie Wire Form 19 75 Mech
36	532 15 50-99	Bushing Strg Nat .623/.618ld
37	532 15 29-27	Screw TT #10-32 x 5 x 3/8 Flange
38	532 17 59-05	Cap Wheel Steer AYP P/L Black
39	819 18 38-12	Washer 9/16 ID x 2-3/8 OD 12 Gr.
40	873 54 06-00	Nut crownlock 3/8-24
41	532 18 67-37	Adaptor Wheel Strg
42	532 16 96-33	Boot Shaft Steering
43	532 12 17-49	Washer 25/32 x 1 1/4 x 16 Ga.
44	532 18 06-40	Extension Steering
46	532 12 12-32	Cap Spindle Fr Top Blk
47	532 18 32-26	Fitting Grease
51	873 54 04-00	Nut Crownlock 1/4-28
54	871 13 04-20	Bolt Hex 1/4-28 unf x 1-1/4 Gr. 8
65	532 16 03-67	Spacer Brace Axle
67	872 11 06-18	Bolt RDHD SQ 3/8-16 unc x 2-1/4
68	532 16 98-27	Brace Axle
71	532 17 51-46	Steering Asm
82	532 16 98-35	Bracket Susp. Chassis Front
88	532 17 51-18	Bolt Shoulder 7/16-20
91	532 17 55-53	Cup Steering
95	532 18 89-67	Washer Hardened

NOTE: All component dimensions given in U.S. inches.
1 inch = 25.4 mm.

REPAIR PARTS

TRACTOR - - MODEL NUMBER REB1192 (REB1192C), PRODUCT NO. 964 79 60-00
SEAT ASSEMBLY

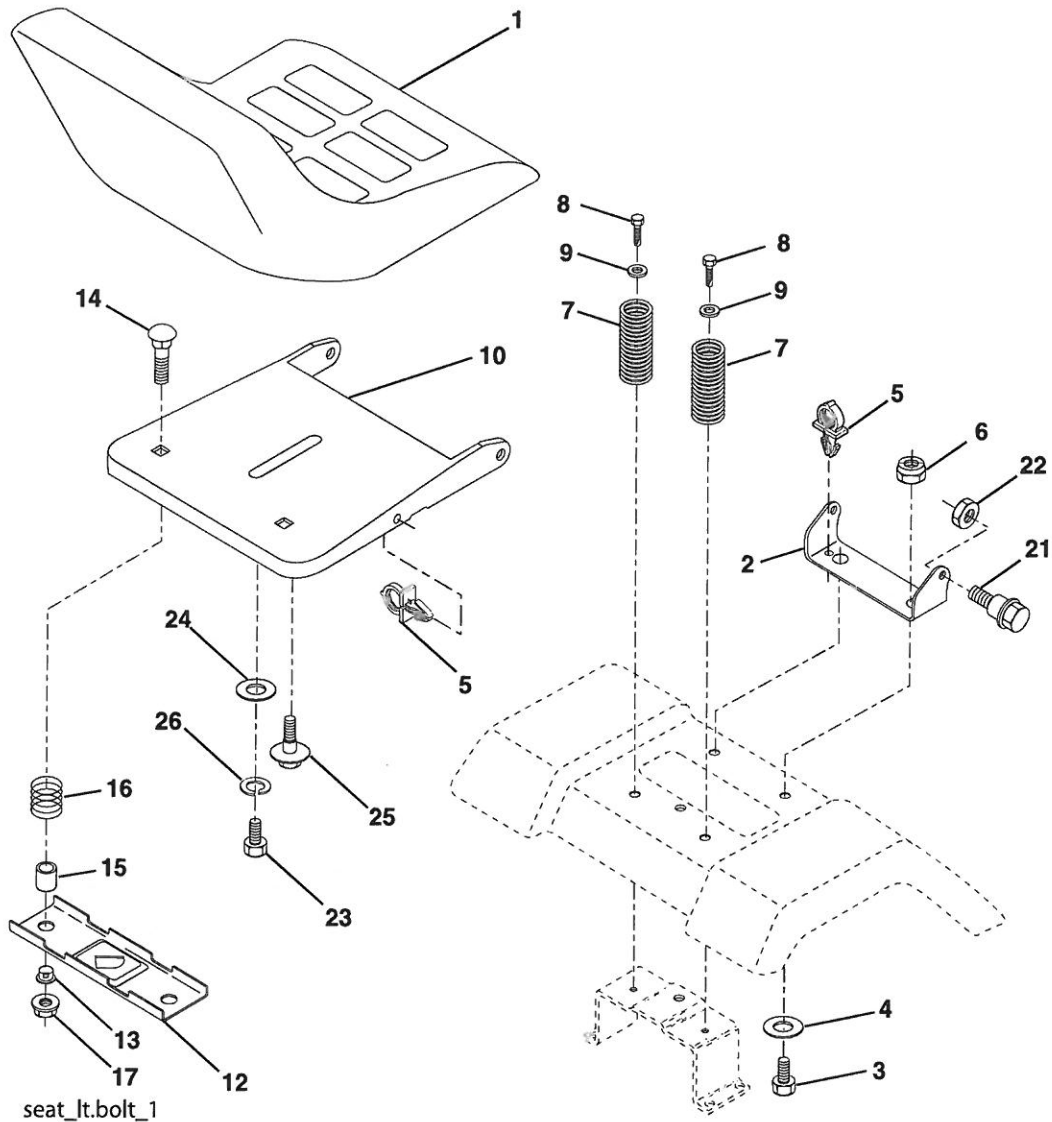

seat_lt.bolt_1

KEY NO.	PART NO.	DESCRIPTION
1	532 17 53-89	Seat
2	532 14 05-51	Bracket Pivot Seat 8 720
3	871 11 06-16	Bolt Fin Hex 3/8-16 unc x 1
4	819 13 16-10	Washer 13/32 x 1 x 10 Ga.
5	532 14 50-06	Clip Push-In
6	873 80 06-00	Nut Lock Hex w/Wsh 3/8-16 unc
7	532 12 41-81	Spring Seat Cprsn 2 250 Blk Zi
8	817 00 06-16	Screw 3/8-16 x 1.5
9	819 13 16-14	Washer 13/32 x 1 x 14 Ga.
10	532 18 24-93	Pan Seat
12	532 12 12-46	Bracket Mounting Switch
13	532 12 12-48	Bushing Snap Blk Nyl 50 ld

KEY NO.	PART NO.	DESCRIPTION
14	872 05 04-12	Bolt Rdhd Sht Nk 1/4-20 x 1-1/2
15	532 13 43-00	Spacer Split 28 x 96 Yel Zinc
16	532 12 12-50	Spring Cprsn 1 27 Blk Pnt
17	532 12 39-76	Nut Lock 1/4 Lge Flg Gr. 5 Zinc
21	532 17 18-52	Bolt Shoulder 5/16-18 unc -2A
22	873 80 05-00	Nut Lock Hex W/Insert 5/16-18 Unc
23	871 11 08-14	Bolt Hex
24	819 17 19-12	Washer 17/32 x 1-3/16 x 12 Ga.
25	532 12 70-18	Bolt Shoulder 5/16-18 x 62
26	810 04 08-00	Washer Lock Hvy HLCLSPR 1/2

NOTE: All component dimensions given in U.S. inches.
1 inch = 25.4 mm

REPAIR PARTS

TRACTOR - - MODEL NUMBER REB1192 (REB1192C), PRODUCT NO. 964 79 60-00
DECALS

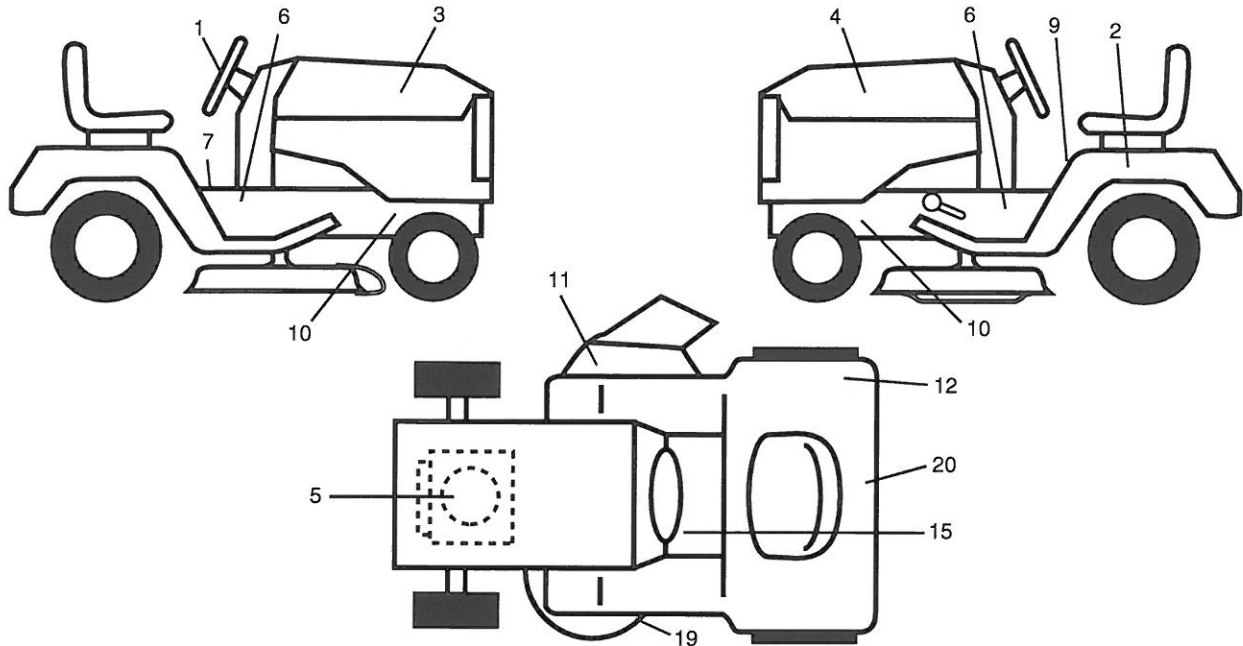

KEY NO.	PART NO.	DESCRIPTION
1	532 14 69-02	Decal Inst Strg Wheel AYP P/L RAL
2	532 14 50-05	Decal Bat Dan/Poi P/L Symbols
3	532 18 76-20	Decal Hood RH
4	532 18 76-21	Decal Hood LH
5	532 18 47-64	Decal Engine
6	532 18 96-95	Decal Chas.
7	532 14 08-37	Decal Saddle Brake Parking
9	532 14 54-98	Decal Read Owners Manual Syms
10	532 15 97-36	Decal Chassis Hot Muffler
11	532 18 21-66	Decal Mower Cut finger Symbol

KEY NO.	PART NO.	DESCRIPTION
12	532 18 04-32	Decal 100 DbA
15	532 15 97-37	Decal Brake/Clutch
19	532 13 68-32	Decal V-Belt Sch
20	532 18 11-46	Decal Logo
--	532 16 25-98	Decal Drawbar Load Limit
--	532 13 83-11	Decal Lift Handle (Lift Handle)
--	532 18 51-49	Manual Operator's Euro
--	532 18 52-38	Manual Operator's Scan
--	532 19 17-28	Manual Parts

WHEELS & TIRES

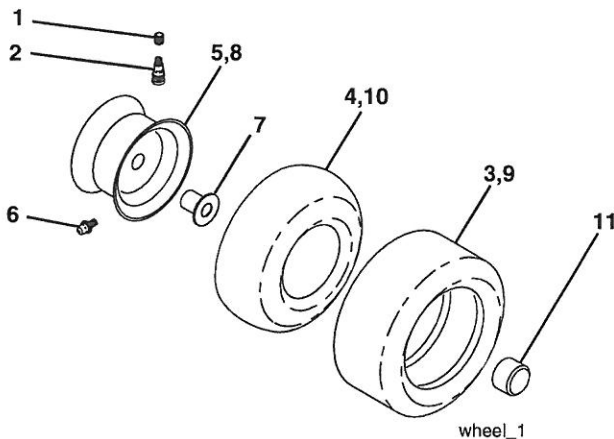

KEY NO.	PART NO.	DESCRIPTION
1	532 05 91-92	Cap Valve Tire
2	532 06 51-39	Stem Valve
3	532 10 62-22	Tire F Ts 15 X 6 - 6 Service
4	532 05 99-04	Tube Front (Service Item Only)
5	532 18 33-37	Rim Asm 6" front Service
6	532 12 49-57	Fitting Grease (Front Wheel Only)
7	532 12 49-59	Bearing Flange (Front Wheel Only)
8	532 18 33-38	Rim Asm 8" rear Service
9	532 10 62-68	Tire R Ts 18 x 9.5-8 C. Service
10	532 12 49-26	Tube Rear (Service Item Only)
11	532 17 50-39	Cap Axle Blk 1 50 X 1 00

NOTE: All component dimensions given in U.S. inches
1 inch = 25.4 mm

REPAIR PARTS

TRACTOR - - MODEL NUMBER REB1192 (REB1192C), PRODUCT NO. 964 79 60-00
ENIGNE

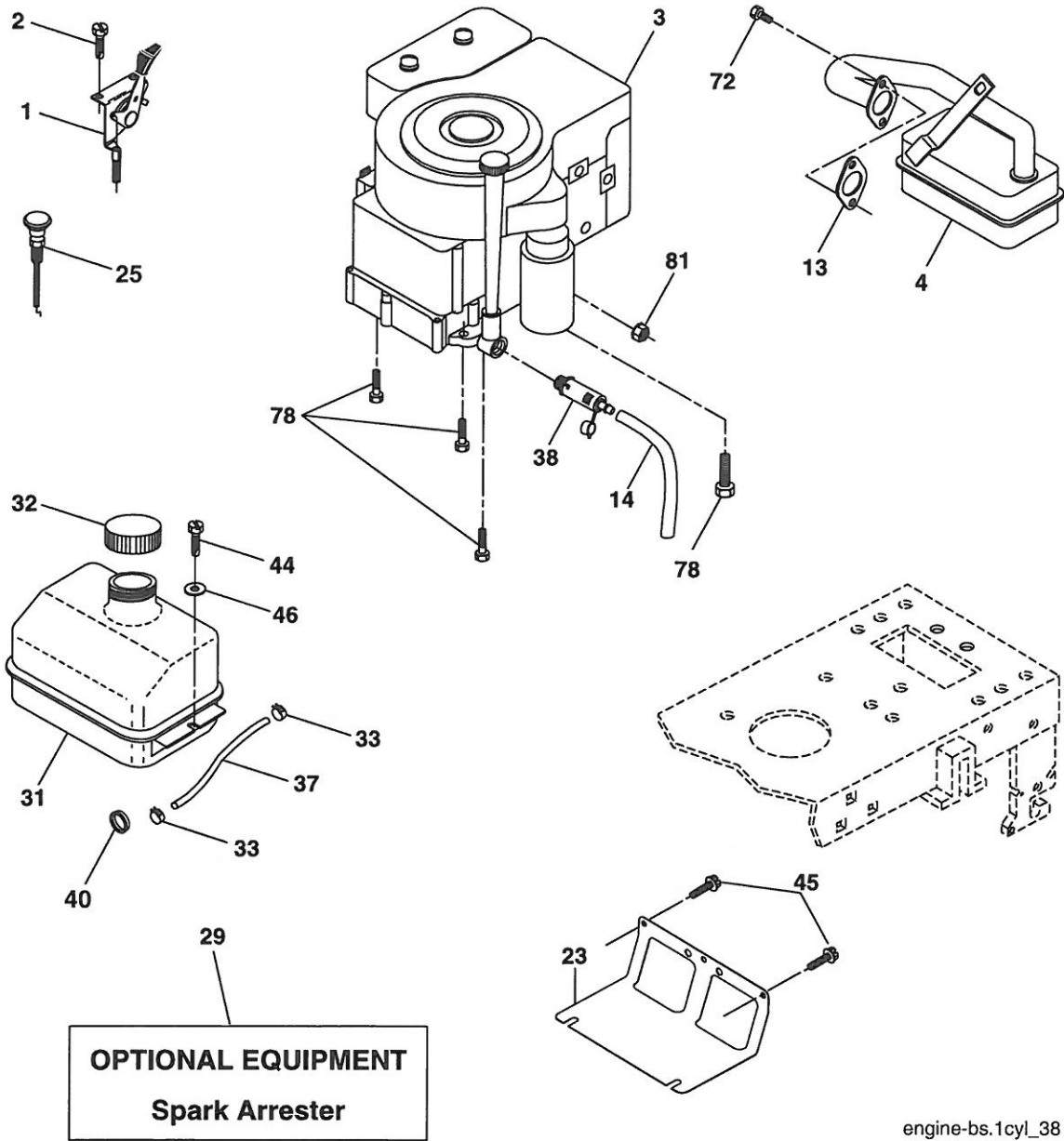

engine-bs.1cyl_38

REPAIR PARTS

TRACTOR - - MODEL NUMBER REB1192 (REB1192C), PRODUCT NO. 964 79 60-00
ENIGNE

KEY NO.	PART NO.	DESCRIPTION
1	532 17 05-51	Control Throttle/Choke Flag
2	817 72 04-08	Screw Hex Thd Cut 1/4-20 x 1/2
3	-----	Engine B&S Model No. 21A807 (Order parts from engine manufacturer)
4	532 17 97-58	Muffler
13	532 16 52-91	Gasket Eng
14	532 14 84-56	Tube Drain Oil Easy
23	532 16 98-37	Shield Brn/Dbr Guard
25	532 19 06-95	Control Choke
29	532 13 71-80	Kit Spark Arrecter
31	532 18 49-00	Tank Fuel Front 1.25
32	532 14 05-27	Cap Asm Fuel W/sym Vented
33	532 12 34-87	Clamp Hose Blk
37	532 13 70-40	Line Fuel 20"
38	532 18 16-54	Plug Oil Drain Easy
40	532 12 40-28	Bushing Snap Nyl Blk Fuel Line
44	817 67 04-12	Screw Hexwsh Thdrol 1/4-20 x 3/4
45	817 00 06-12	Screw Hexwsh Thdrol 3/8-16 x 3/4
46	819 09 14-16	Washer 9/32 x 7/8 x 16 Ga.
72	532 18 39-06	Screw Socket Head 5/16-18 x 1
78	817 06 06-20	Screw 3/8-16 x 1-1/4
81	873 51 04-00	Nut Keps Hex 1/4-20 unc

NOTE: All component dimensions given in U.S. inches
1 inch = 25.4 mm

REPAIR PARTS

TRACTOR - - MODEL NUMBER REB1192 (REB1192C), PRODUCT NO. 964 79 60-00
MOWER LIFT

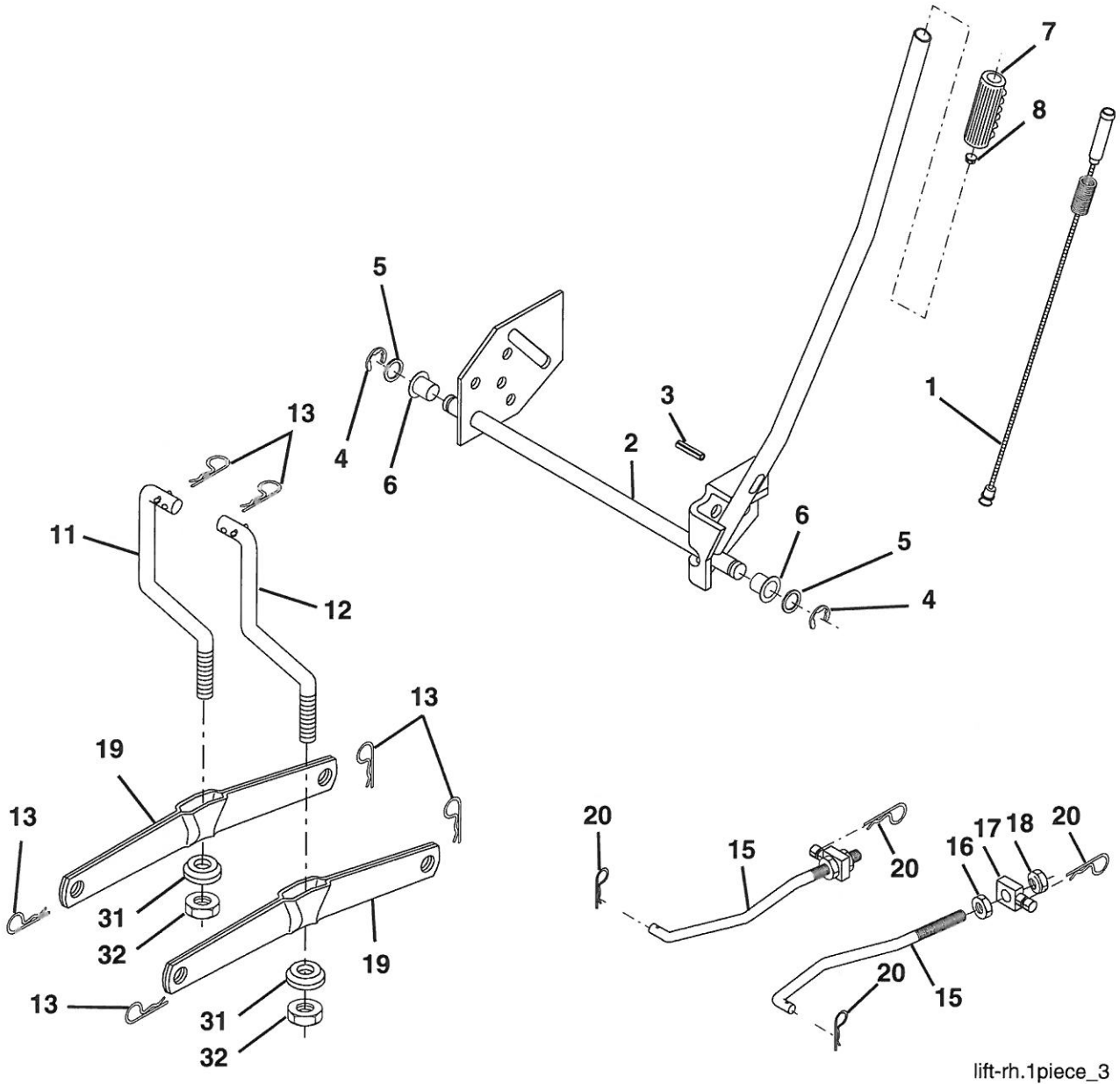

lift-rh.1piece_3

REPAIR PARTS

TRACTOR - - MODEL NUMBER REB1192 (REB1192C), PRODUCT NO. 964 79 60-00
MOWER LIFT

KEY NO.	PART NO.	DESCRIPTION
1	532 15 94-61	Wire Asm Inner W/Plunger
2	532 15 94-76	Shaft Asm Lift
3	532 18 88-22	Pin Groove
4	812 00 00-02	E Ring #5133-62
5	819 21 16-21	Washer PLTD 21/32 x 1 x 21Ga.
6	532 12 01-83	Bearing Nylon Blk 629 Id
7	532 10 94-13	Grip Handle Bicycle Matte Blk
8	532 12 45-26	Button Plunger Black
11	532 13 98-65	Link Lift LH
12	532 13 98-66	Link Lift RH
13	532 12 46-70	Retainer Spring
15	532 17 32-88	Link Front
16	873 35 08-00	Nut Jam Hex 1/2-13 unc
17	532 17 56-89	Trunnion
18	873 80 08-00	Nut Lock W/Wsh 1/2-13 unc
19	532 13 98-68	Arm Suspension Rear
20	532 16 35-52	Retainer Spring
31	532 16 98-65	Bearing Pvt Lift
32	873 54 06-00	Nut Crownlock 3/8-24

NOTE: All component dimensions given in U.S. inches
1 inch = 25.4 mm

REPAIR PARTS

TRACTOR - - MODEL NUMBER REB1192 (REB1192C), PRODUCT NO. 964 79 60-00
MOWER

KEY NO.	PART NO.	DESCRIPTION
1	532 17 45-95	Mower Deck Assembly
2	872 14 05-06	Bolt
3	532 13 80-17	Bracket Assembly,Sway Bar
4	532 17 56-54	Bracket Sway Bar
5	532 12 46-70	Retainer Spring
6	532 17 80-24	Bar Sway Deck
7	532 14 06-08	Keeper Belt
8	532 85 08-57	Bolt, Hex 3/8-24 x 1.25 Gr. 8
9	810 03 06-00	Washer, Lock Hvy Hlcl 3/8
10	532 14 02-96	Washer,Hardened
11	532 13 84-96	Blade, Mower
13	532 13 76-45	Shaft Assembly, Mandrel, Vented
14	532 12 87-74	Housing, Mandrel, Vented
15	532 11 04-85	Bearing, Ball, Mandrel
16	532 17 44-93	Stripper, Mower Deck
19	532 13 28-27	Bolt, Shoulder
21	873 68 05-00	Nut Crownlock 5/16-18
23	532 13 66-31	Bracket, Mower Deflector
24	532 10 53-04	Cap, Sleeve
25	532 12 37-13	Spring, Torsion, Deflector
26	532 11 04-52	Nut, Push
27	532 17 61-62	Shield, Deflector
28	819 11 10-16	Washer 11/32 x 5/8 x 16 Ga.
29	532 12 19-80	Rod, Hinge
30	532 17 39-84	Screw Thdrol
31	532 18 76-90	Washer, Spacer
32	532 15 35-31	Pulley, Mandrel
33	532 17 83-42	Nut, Toplock, Flanged
34	872 11 06-14	Bolt Rdhd 3/8-16 x 1-3/4
36	532 13 14-94	Pulley, Idler, Flat
40	873 68 06-00	Nut Crownlock 3/8-16
45	532 12 47-88	Retainer, Spring
53	532 13 08-40	Brake Assembly
54	532 17 85-15	Washer,Hardened
55	532 13 38-40	Idler Arm Assembly
56	532 16 57-23	Spacer, Retainer
67	532 10 69-32	Knob RD 3/8-16 Plstc Thd
68	532 18 02-13	Belt
89	819 13 13-11	Washer 13/32 x 13/16 x 11 Ga.
107	532 13 35-02	Spacer, Retainer
108	532 13 35-03	Stiffener, Idler Arm
113	817 49 05-08	Screw Thdrol 5/16-18 x 1/2
122	532 17 45-05	Rod, Brake, LH
123	532 17 45-04	Rod, Brake, RH
146	532 16 58-91	Bolt Carriage Idler
148	532 16 90-22	Spring Return Idler
149	532 16 58-98	Retainer Spring Yellow Zinc
150	819 09 12-10	Washer 9/32 x 3/4 x 10 Ga.
152	532 17 60-79	Cable Clutch
158	817 72 04-08	Screw Hex Thd Cut 1/4-20 x 1/2
164	532 17 49-76	Bracket Asm Idler Support
168	532 17 23-77	Bracket Deck Cable
169	532 17 49-77	Bracket Asm Suspension
170	532 17 23-59	Bracket Suspension RF
171	532 16 52-37	Brace Support Susp. Frt
172	532 17 23-55	Bracket Suspension LF
185	532 18-82-34	Head Asm Cable Clutch
--	532 13 07-94	Mandrel Assembly (Includes Housing, Shaft and Shaft Hardware Only - Pulley Not Included)
--	532 18 13-76	Replacement Mower,Complete

NOTE: All component dimensions given in U.S. inches
1 inch = 25.4 mm



SERVICE POLICY WARRANTY



Issued January 1980
Revised January 1991

LIMITED WARRANTIES FOR NEW PEERLESS GEAR POWER TRAIN COMPONENTS

A. Products Warranted

Peerless Gear and Machine Division of Tecumseh Products Company ("Tecumseh"), subject to the limitations contained below, will, at its option, repair or replace, without charge for parts or labor only, any part of a new Power Train Component (which as used herein means and includes the transaxle, gear box, transmission, differential and right angle drives, and any part of the Power Train Component), EXCEPT any new Power Train Component incorporated in equipment used for commercial or rental purposes, which is found upon examination by any Tecumseh Authorized Service Outlet or by Tecumseh's factory in Grafton, Wisconsin, to be DEFECTIVE IN MATERIAL AND/OR WORKMANSHIP if received by Tecumseh or a Tecumseh Authorized Service Outlet for such examination within TWO YEARS from the date of sale to the original consumer purchaser of Peerless Series 820, 900, 910, 915, 920, 930 transaxles and Series 1100 angle drive and ONE YEAR for all other Peerless products. New Power Train Components incorporated in equipment used for commercial purposes are warranted in the same manner and to the same extent EXCEPT such Power Train Components are warranted for NINETY (90) DAYS ONLY, and must be received by Tecumseh or by a Tecumseh Authorized Service Outlet for such examination within 90 days from the date of sale to the original purchaser. New Power Train Components incorporated in equipment used for rental purposes are warranted in the same manner and to the same extent EXCEPT such Power Train Components are warranted for THIRTY (30) DAYS ONLY, and must be received by Tecumseh or a Tecumseh Authorized Service Outlet within 30 days from the date of sale to the original purchaser.

B. Products And Items Not Warranted

1. Alterations or Modifications of Power Train Components.
2. Accidents, Normal Maintenance, Failure to follow the Original Equipment Manufacturer's Manual.

This warranty covers only parts of new Power Train Components which are found upon examination to be defective in material or workmanship as delivered to the original purchaser. This warranty does not cover defects caused by depreciation or damage caused by normal wear, accidents, improper maintenance, improper use or abuse of the product, failure to follow the instructions contained in an Instruction Manual for the operation of the Power Train Component and parts. The cost of normal maintenance and replacement of service items which are not defective shall be paid for by the original purchaser.

C. Securing Warranty Service

Warranty service can be arranged for by contacting either a Tecumseh Authorized Service Outlet (any Tecumseh Registered Service Dealer, Tecumseh Authorized Service Distributor, or Tecumseh Central Warehouse Distributor) or by contacting Tecumseh, c/o Service Manager, Engine and Transmission Group Service Division, 900 North Street, Grafton, Wisconsin 53024. Warranty service can only be performed by a Tecumseh Authorized Service Outlet or by Tecumseh at its factory in Grafton, Wisconsin. At the time of requesting warranty service, evidence must be presented of the date of sale to the original purchaser. The purchaser shall pay any charges for making service calls and/or for transporting the product to and from the place where the inspection and/or warranty work is performed. The purchaser shall be responsible for any damage or loss incurred in connection with the transportation of Power Train Components and/or part(s) of the Power Train Components submitted for inspection and/or warranty work.

D. Limitation of Damages and Implied Warranties

The foregoing EXPRESSED WARRANTY IS IN LIEU OF ALL OTHER EXPRESS WARRANTIES. Neither Tecumseh nor any of its affiliates makes any warranties, representations or promises, written or oral, as to the quality of the Power Train Component or any of its parts, other than as set forth herein.

ANY IMPLIED WARRANTY OF MERCHANTABILITY OR FITNESS FOR A PARTICULAR PURPOSE, TO THE EXTENT THAT EITHER MAY APPLY TO ANY PART(S) OF POWER TRAIN COMPONENTS, SHALL BE LIMITED IN DURATION TO THE PERIODS OF THE EXPRESSED WARRANTIES DEFINED IN PARAGRAPH A HEREOF. IN NO EVENT WILL TECUMSEH BE LIABLE FOR ANY INCIDENTAL, CONSEQUENTIAL OR SPECIAL DAMAGES AND/OR EXPENSES. Some states do not allow limitations on how long an implied warranty lasts or the exclusion or limitation of incidental or consequential damages, so the above limitation(s) or exclusion(s) may not apply to you. This warranty gives you specific legal rights and you may also have other legal rights which vary from state to state.

E. No Dealer Warranty

Tecumseh neither assumes nor authorizes any other person, natural or corporate, to assume for Tecumseh any other obligations or liabilities in connection with or with respect to any part(s) of a Power Train Component. The seller or dealer of part(s) of a Power Train Component has no authority, whatsoever, to make any representations or promises on behalf of Tecumseh or to modify the terms or limitations of Tecumseh's warranty in any way.

Rally