

ASSEMBLY/REPAIR PARTS
Model No. CH1238A
Lawn Tractor

Red Tin bonnet.



CHAMPION

12 HP 38" TRACTOR -- MODEL NUMBER CH1238A

SCHEMATIC

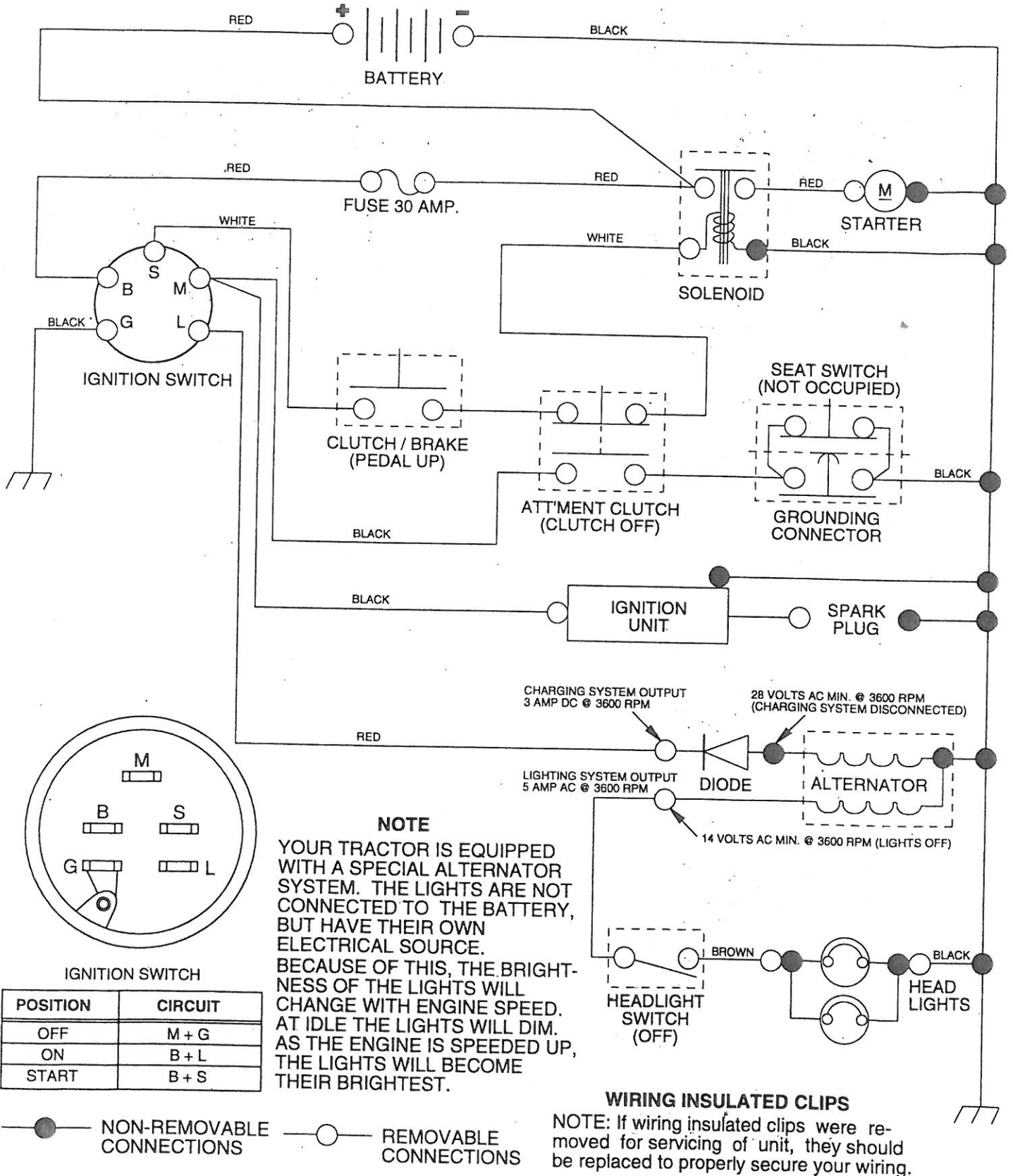

REPAIR PARTS

12 HP 38" TRACTOR -- MODEL NUMBER CH1238A

DECALS

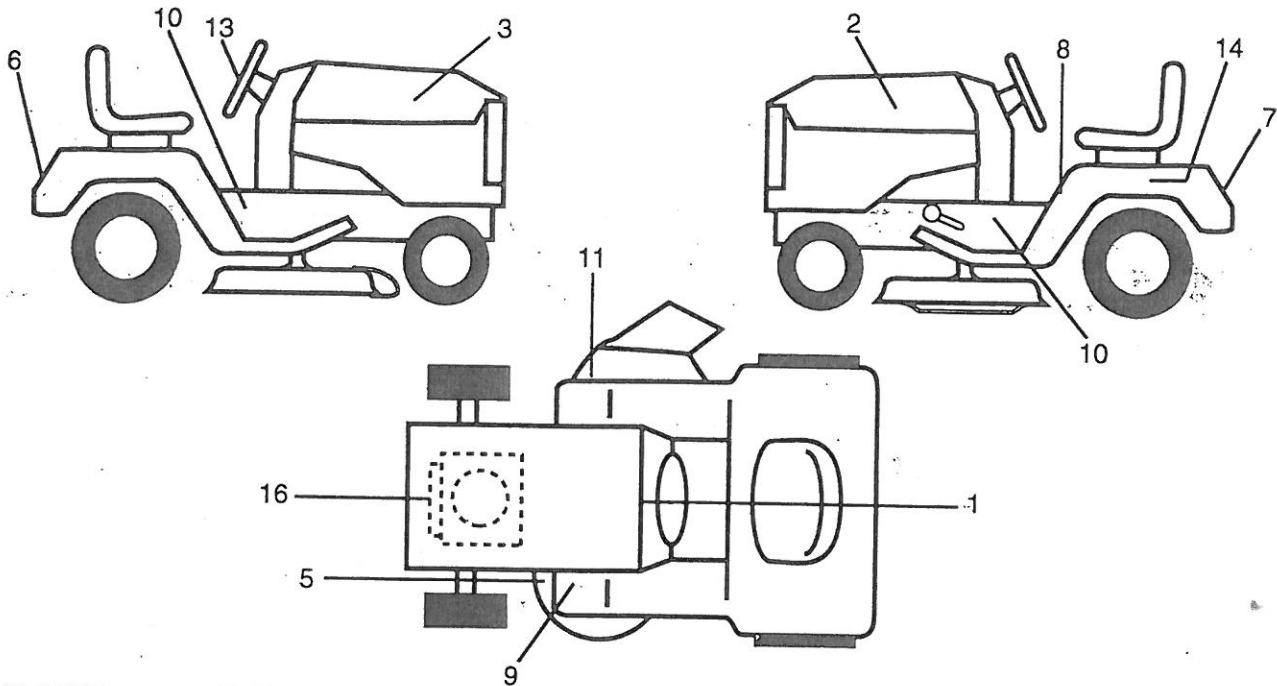

KEY PART NO. NO.

DESCRIPTION

1	138955	Decal, Instruction, Operating
2	139680	Decal, Hood, Stripe L.H.
3	139679	Decal, Hood, Stripe R.H.
5	136832	Decal, V-Belt Schematic
6	139676	Decal, Fender
7	125690X	Decal, 100 DBA
8	133796	Decal, Caution
9	4900J	Decal, Clutch/Brake
10	127035	Decal, Chassis, Speed/Deck Size
11	137259	Decal, Warning
13	139677	Decal, Steering Wheel Insert
14	121549X	Decal, Caution, Battery

KEY PART NO. NO.

DESCRIPTION

16	120601X	Decal, Engine
—	138311	Decal, Handle Lift (Lift Handle)
—	137372	Manual, Operator's
—	139870	Manual, Parts

Accessories available (not included with tractor):

--	CE38	Grass Catcher for 38"
--	CH12	Tire Chains (18 x 8.5 x 8 Turf)
--	Bd20	42" Snow Blade
--	LC02	33 lb Wheel wts. (pair)
--	SB20	40" Snow Thrower

WHEELS & TIRES

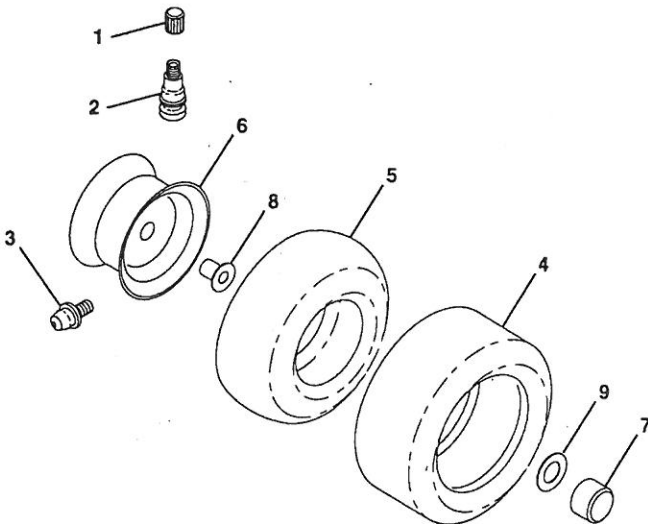

KEY PART NO. NO.

DESCRIPTION

1	59192	Cap, Valve
2	65139	Stem, Valve
3	278H	Fitting, Grease
4	124635X	Tire, Rear
4	106222X	Tire, Front
5	7152J	Tube, Rear (Opt. Serv. Items Only)
5	59904	Tube, Front (Opt. Serv. Items Only)
6	106108X311	Rim, Assembly, Rear
6	106732X311	Rim, Assembly, Front
7	104757X	Cap, Axle
8	9040H	Bearing, Flange (Front Wheels Only)
9	121748X	Washer 25/32 x 1-5/8 x 16 Ga.

NOTE: All component dimensions given in U.S. inches.
1 inch = 25.4 mm

REPAIR PARTS

12 HP 38" TRACTOR - - MODEL NUMBER CH1238A

ELECTRICAL

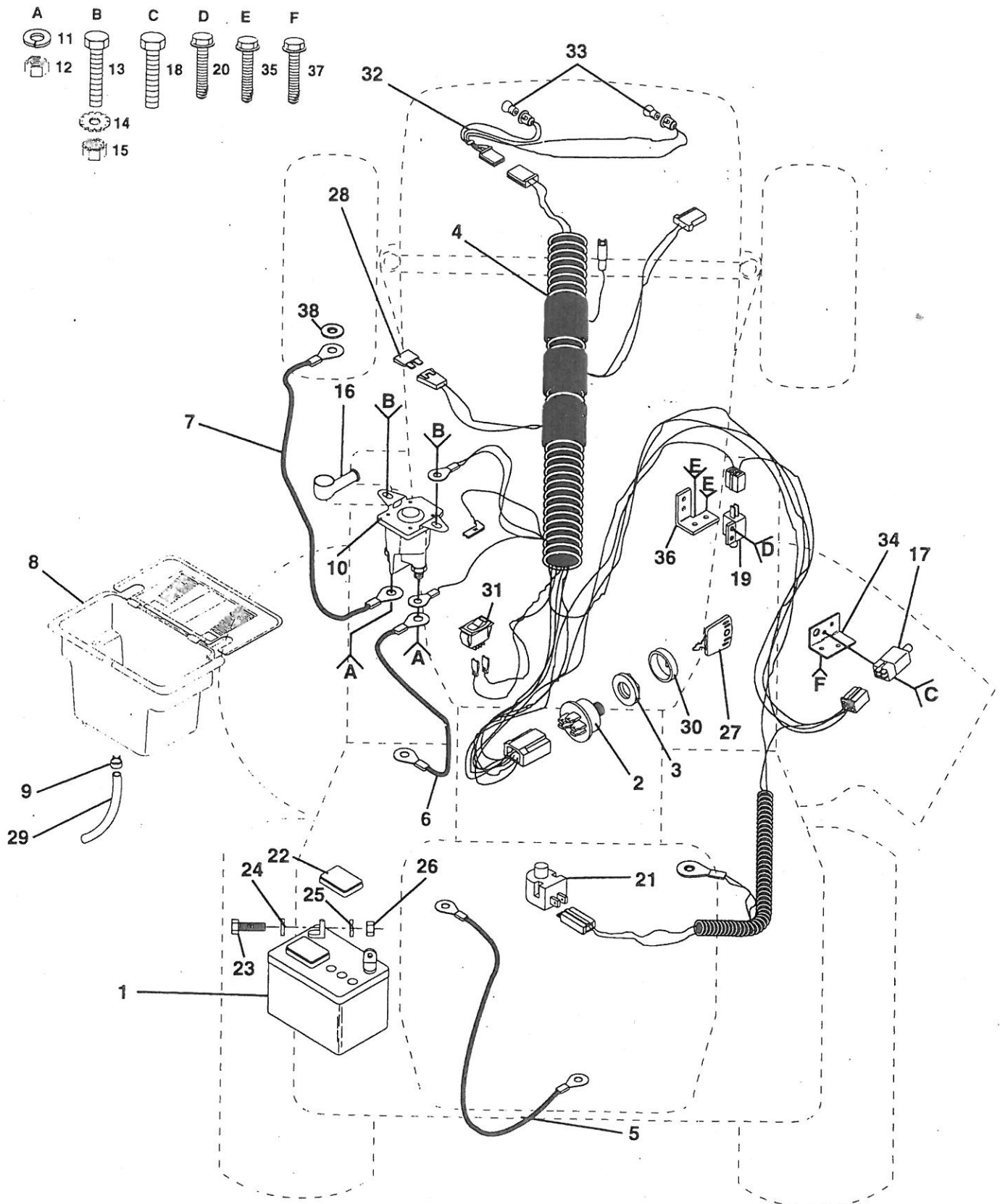

REPAIR PARTS

12 HP 38" TRACTOR - - MODEL NUMBER CH1238A

ELECTRICAL

KEY NO.	PART NO.	DESCRIPTION
1	121265X	Battery 12 VOLT 25 AMP
2	4406R	Switch Ign 5 Term Wo/wash/nut
3	124211X	Nut Ignition
4	132017	Harness Ign Bs/tec Dash HI
5	4207J	Cable Ground 6 Ga 12"black
6	132202	Cable Battery 6 Ga 43"red
7	4799J	Cable Battery 6 Ga 11"red
8	129965	Case Battery Hinge Mech W/Lid
9	109596X	Clamp Hose Olive
10	138406	Solenoid
11	10090400	Washer Lock 1/4
12	73350400	Nut Jam Hex 1/4-20 Unc
13	74780408	Bolt Fin Hex 1/4-20uncx1/2 Gr5
14	11050400	Washer Lock Ext Tooth 1/4
15	73510400	Nut Keps Hex 1/4-20 Unc
16	131563	Cover Terminal Red
17	109553X	Switch Intlk Clutch Gry 4 Term
18	17021008	Screw Tap Hex #10-24unc X 1/2
19	104445X	Switch Intlk Clutch Gry 2 Term
20	17021008	Screw Tap Hex #10-24unc X 1/2
21	121305X	Switch Plunger Nc Gray
22	121264X	Caps Battery 20/25/30 AMP
23	74760412	Bolt Hex Hd 1/4-20unc X 3/4
24	19091016	Washer 9/32 X 5/8 X 16 Ga
25	10040400	Washer Lock Hvy Helical 1/4
26	73220400	Nut Fin Hex 1/4-20 Unc
27	122147X	Key Ign Molded Generic
28	108824X	Fuse 30 AMP Auto Green
29	109238X	Tube Plastic 12"
30	123620X	Cover Sw Key Blk 1 25 Text SLT
31	110712X	Switch Light Blk Blk Red
32	136849	Harness Asm Light W/7662j
33	7662J	Bulb Light #1141
34	108236X	Bracket Switch Clutch
35	17021008	Screw Tap Hex #10-24unc X 1/2
36	130890	Bracket Switch Interlock
37	17021008	Screw Tap Hex #10-24unc X 1/2
38	11150400	Washer Lock Internal Tooth 1/4

NOTE: All component dimentions given in U. S. inches.
1 inch = 25.4 mm

REPAIR PARTS

12 HP 38" TRACTOR - - MODEL NUMBER CH1238A

CHASSIS AND ENCLOSURES

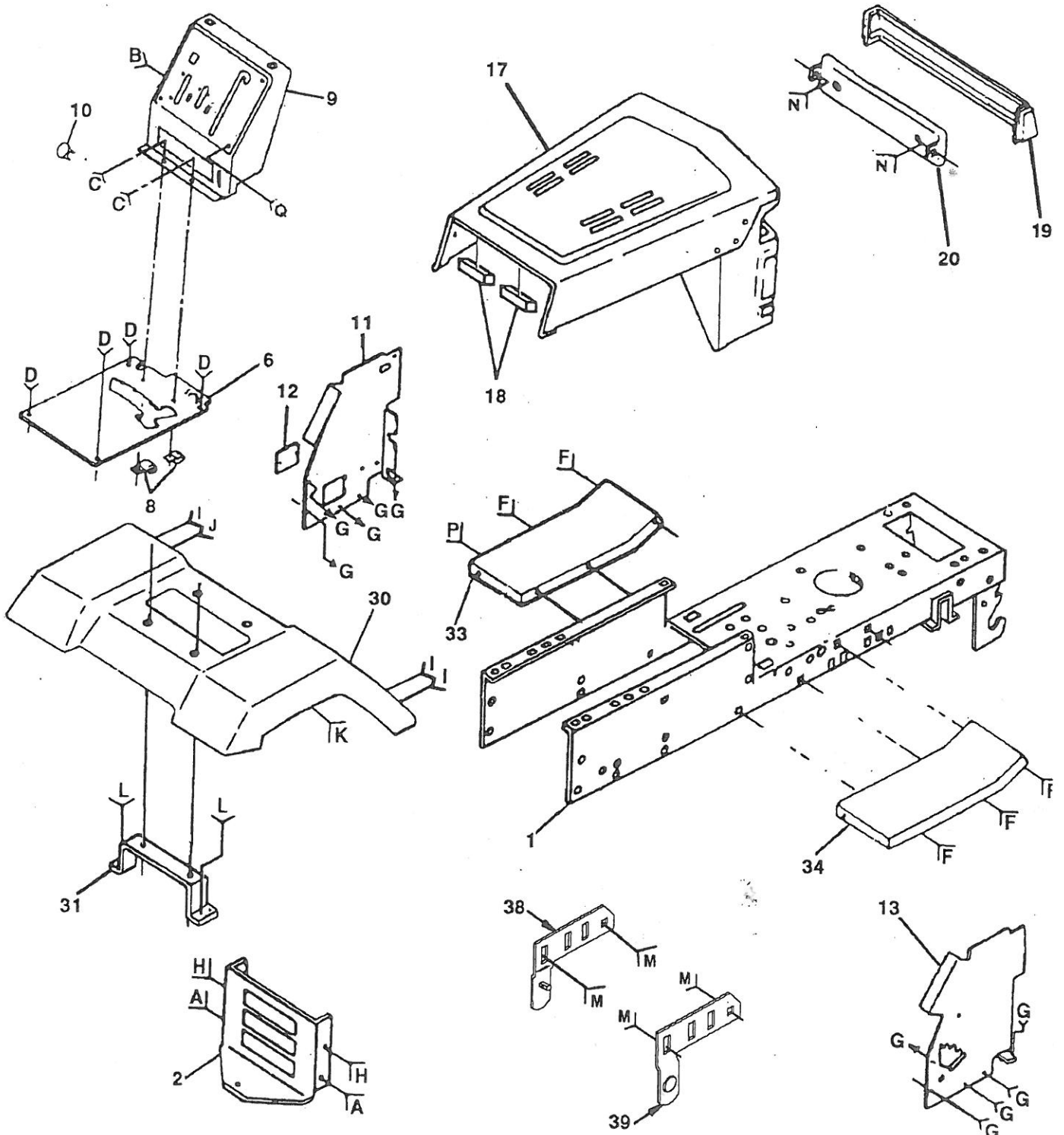
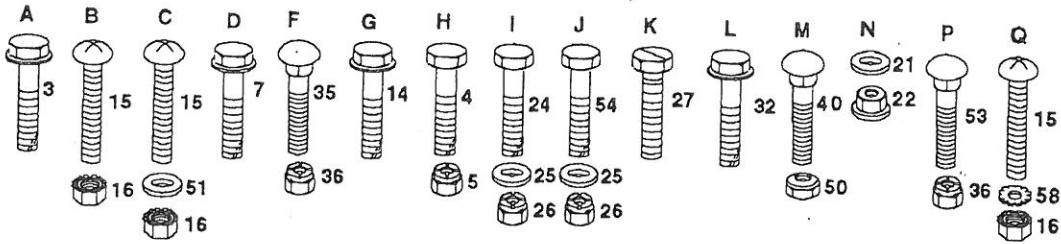

REPAIR PARTS

12 HP 38" TRACTOR -- MODEL NUMBER CH1238A

CHASSIS AND ENCLOSURES

KEY NO.	PART NO.	DESCRIPTION
1	135034	Chassis Wldmt 11 Ga 38/42 W/pvt
2	137275	Drawbar LT/YT 11 Ga
3	17490612	Screw Thdrol 3/8-16x3/4 Ty-tt
4	74760612	Bolt Fin Hex 3/8-16unc X 3/4
5	73680600	Nut Crownlock 3/8-16 Unc
6	124464X017	Saddle
7	17490608	Screw Thdrol 3/8-16x1/2 Ty-tt
8	2751R	Clip Line Fuel 13/32 Mtg Hole
9	137411X012	Dash
10	5479J	Plug Button Blk 359 Dia Choke
11	122795X	Panel Dash LH
12	121794X	Cover Access Black Square
13	124031X012	Panel RH Dash
14	17490608	Screw Thdrol 3/8-16x1/2 Ty-tt
15	74180512	Screw Mach TRHD 5/16-18uncx3/4
16	73510500	Nut Keps 5/16-18 Unc
17	133956X505	Hood/Grill Asm.
18	126938X	Bumper Hood
19	133805	Lens Grille H/bar Clear Lt
20	132257	Bezel Light
21	19091216	Washer 9/32 X 3/4 X 16Ga
22	108067X	Nut Pal
24	74760612	Bolt Fin Hex 3/8-16unc X 3/4
25	19131312	Washer 13/32 X 13/16 X 12 Ga
26	73680600	Nut Crownlock 3/8-16 Unc
27	17490608	Screw Thdrol 3/8-16x1/2 Ty-tt
30	109872X505	Fender
31	136619	Bracket Fender Repl 10973x
32	17490612	Screw Thdrol 3/8-16x3/4 Ty-tt
33	105476X505	Footrest LH Perf
34	105475X505	Footrest RH Perf
35	72110606	Bolt Rdhd Sht Sqnk 3/8-16 X3/4
36	73680600	Nut Crownlock 3/8-16 Unc
38	134618	Bracket Asm Pvt38 LH MWR Rear
39	134617	Bracket Asm Pvt38 RH MWR Rear
40	72140608	Bolt RDHD SQNK 3/8-16 x 1
50	73800600	Nut Lock Hex W/wsh 3/8-16unc
51	19131216	Washer 13/32 X 3/4 X 16 Ga
53	72140608	Bolt Rd Sqnk 3/8 - 16 X 1
54	74760614	Bolt Fin Hex 3/8 - 16 X 7/8
58	11050600	Washer Lock Ext Tooth 3/8

NOTE: All component dimensions given in U.S. inches.
1 inch = 25.4 mm

REPAIR PARTS

12 HP 38" TRACTOR -- MODEL NUMBER CH1238A

DRIVE

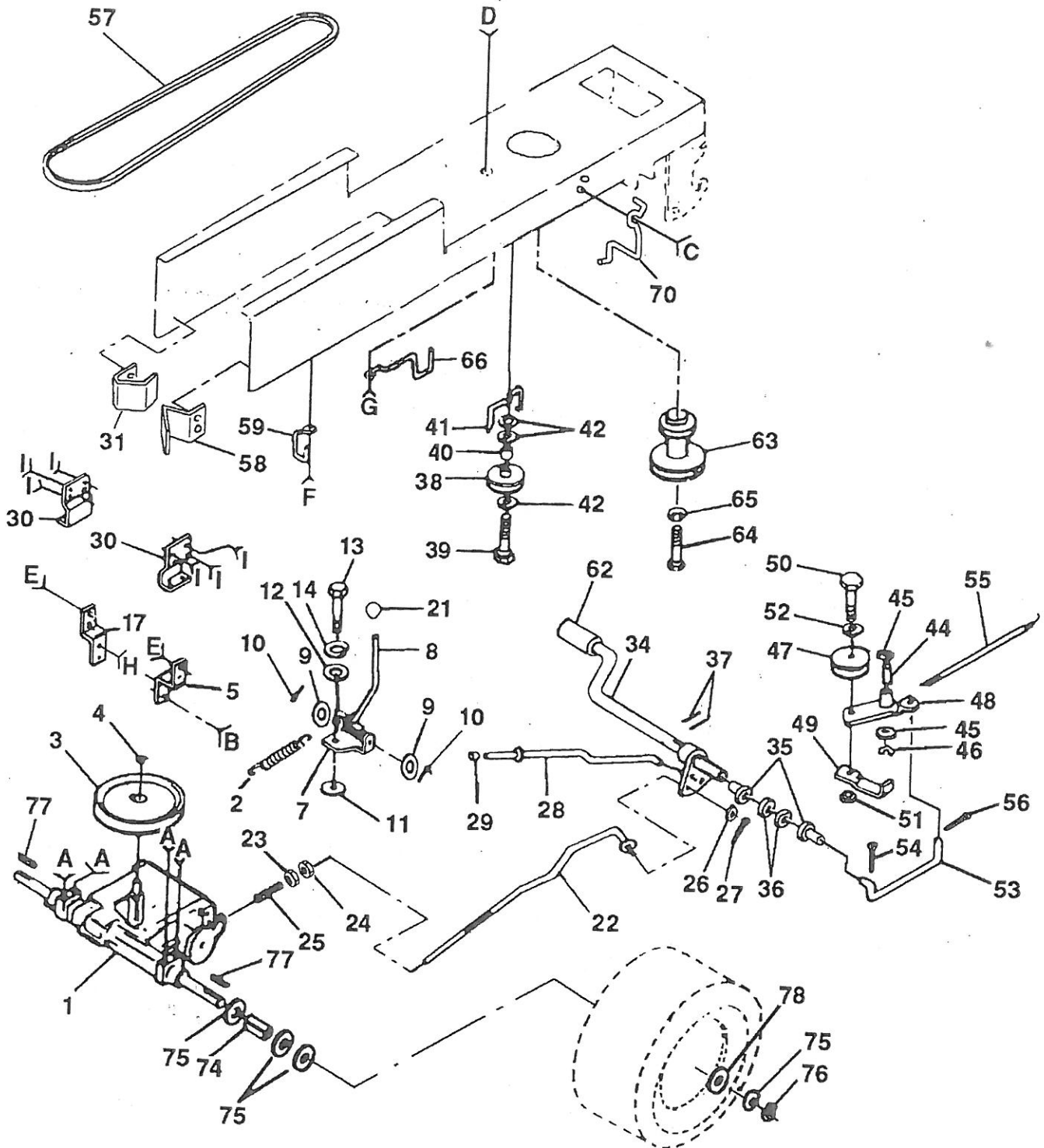

- | | | | | | | | | |
|----------|----------|----------|----------|----------|----------|----------|----------|----------|
| A | B | C | D | E | F | G | H | I |
| 15 | 6 | 71 | 43 | 18 | 61 | 67 | 20 | 32 |
| 79 | | 72 | | 19 | 60 | 68 | | 33 |
| 16 | | 73 | | | | 69 | | |

REPAIR PARTS

12 HP 38" TRACTOR - - MODEL NUMBER CH1238A

DRIVE

KEY NO.	PART NO.	DESCRIPTION	KEY NO.	PART NO.	DESCRIPTION
1	137363	Transaxle 6sp Std D4360-48	42	19131312	Washer 13/32 X 13/16 X 12 Ga
2	110422X	Spring Return Brake T/a Zinc	43	73680600	Nut Crownlock 3/8-16 Unc
3	123666X	Pulley Transaxle 18"tires	44	105706X	Bearing Nyl 503 X 628 X 1 25
4	12000028	Ring Retainer # 5100-62	45	110812X	Washer Hardened
5	121520X	Strap Torque 30 Degrees	46	12000039	Ring Klip #5304-50
6	17490512	Screw Thdrol 5/16-18 X 3/4 TYT	47	127783	Pulley Idler V Groove Plastic
7	106919X	Plate Rod Shift	48	123789X	Bellcrank Asm Clutch
8	124461X	Rod Shf Sdl LY/YT Str Blk Zinc	49	123205X	Retainer Belt Style Spring
9	19151216	Washer 15/32 X 3/4 X 16 Ga	50	74760624	Bolt Hex Hd 3/8-16unc X 1-1/2
10	76020416	Pin Cotter 1/8 X 1 Cad	51	73680600	Nut Crownlock 3/8-16 Unc
11	105701X	Washer Plate Shf 388 Sq Hole	52	19131316	Washer 13/32 X 13/16 X 16 Ga
12	19091210	Washer 9/32 X 3/4 X 10 Ga	53	105710X	Link Clutch 7 66
13	71040412	Bolt Fin Hex 1/4-28unfx3/4 Gr8	54	76020412	Pin Cotter 1/8 X 3/4 Cad
14	10040400	Washer Lock Hvy Helical 1/4	55	105709X	Spring Return Clutch 6 75
15	74760644	Bolt Fin Hex 3/8-16uncx 2-3/4	56	76020412	Pin Cotter 1/8 X 3/4 Cad
16	73680600	Nut Crown Lock 3/8-16 Unc	57	125907X	V-Belt Ground Drive 95 25 42"
17	121520X	Strap Torque 30 Degrees	58	127274X	Keeper Belt RH LT Pnt/zinc 16g
18	74760612	Bolt Fin Hex 3/8-16unc X 3/4	59	136715	Keeper Belt Chassis
19	73680600	Nut Crownlock 3/8-16 Unc	60	19131312	Washer 13/32 x 13/16 x 12 Ga
20	17490512	Screw Thdrol 5/16-18 X 3/4 TYT	61	17490612	Screw Thdrol 3/8-16 x 3/4 Ty-tt
21	106279X	Knob Rd 1/2-13 Plstc Thds Yel	62	8883R	Cover Pedal Blk Round
22	131867	Rod Brake	63	134825	Engine Pulley LT/YT
23	73800600	Nut Lock Hex W/wsh 3/8-16unc	64	71170764	Bolt Hex 7/16-20x4 Gr 5
24	73350600	Nut Hex Jam 3/8-16 Unc	65	10040700	Washer Lock Hvy Hlcl Spr 7/16
25	106888X	Spring Rod Brake 2 00 Zinc	66	129921	Keeper Belt Engine LH LT
26	19131316	Washer 13/32 X 13/16 X 16 Ga	67	74760616	Bolt Fin Hex 3/8-16unc X 1
27	76020412	Pin Cotter 1/8 X 3/4 Cad	68	19131312	Washer 13/32 X 13/16 X 12 Ga
28	128904	Rod Brake Parking LT	69	73680600	Nut Crownlock 3/8-16 Unc
29	7733J	Cap Parking Brake Yellow	70	134683	Guide Belt Mower Drive RH
30	109167X	Bracket Mtg Transaxle	71	74760616	Bolt Fin Hex 3/8-16unc X 1
31	127275X	Keeper Belt LH LT 14 Ga	72	19132012	Washer 13/32 X 1-1/4 X 12 Ga
32	74760616	Bolt, Fin Hex 3/8-16 Unc x 1	73	73680600	Nut Crownlock 3/8-16 Unc
33	73680600	Nut, Crownlock 3/8-16 Unc	74	109502X	Spacer Split 80x1 94 Cad/zinc
34	122424X	Shaft Asm Pedal Foot 1 930	75	121749X	Washer 25/32 X 1 1/4 X 16 Ga
35	120183X	Bearing Nylon Blk 629 Id	76	12000001	E-ring #5133-75
36	19211616	Washer 21/32 X 1 X 16 Ga	77	123583X	Key Square 2 0 X 1845/ 1865
37	1572H	Pin Roll 3/16 X 1"	78	121748X	Washer 25/32 X 1-5/8 X 16 Ga
38	123674X	Pulley Idler Flat	79	19131216	Washer 13/32 x 3/4 x 16 Ga.
39	74760644	Bolt Fin Hex 3/8-16unc X 2-3/4			
40	4470J	Spacer Split 395 X 59 Bzp			
41	109070X	Keeper Belt Retainer			

NOTE: All component dimensions give in U.S. inches.
1 inch = 25.4 mm.

REPAIR PARTS

12 HP 38" TRACTOR -- MODEL NUMBER CH1238A

STEERING AND FRONT AXLE

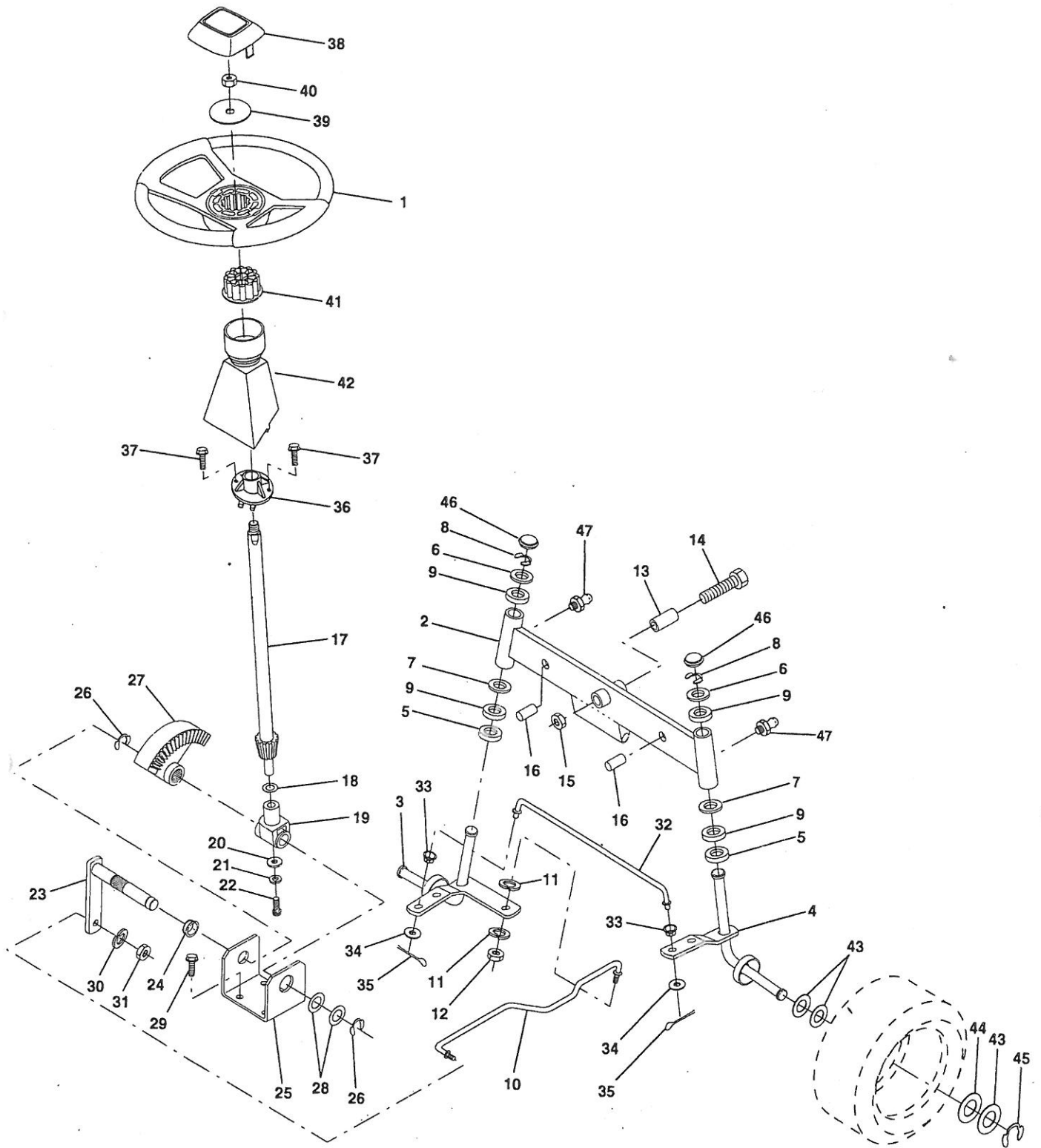

REPAIR PARTS

12 HP 38" TRACTOR - - MODEL NUMBER CH1238A

STEERING AND FRONT AXLE

KEY PART NO.	NO.	DESCRIPTION
1	133741	Wheel, Steering
2	133988	Axle, Front
3	135227	Spindle, L.H.
4	135228	Spindle, R.H.
5	6266H	Bearing, Thrust
6	121748X	Washer 27/32 x 1-1/4 x 16 Ga.
7	19272016	Washer 27/32 x 1-1/4 x 16 Ga.
8	12000029	Ring Klip
9	3366R	Bearing
10	130468	Link, Drag
11	10040600	Washer, Lock 3/8
12	73610600	Nut, Hex 3/8-24
13	110438X	Spacer, Bearing, Front Axle
14	74011056	Bolt, Hex 5/8-11 x 3-1/2
15	73901000	Nut, Lock Flange 5/8-11 Unc
16	132624	Pin, Axle 5/8 x 1.55/1.54 Lg.
17	132614	Shaft, Steering
18	57079	Washer
19	124035X	Shaft, Support
20	126684X	Washer 5/8 x 1/4 x 16 Ga.
21	10040400	Lock Washer 1/4
22	71070410	Screw, Socket Hex 1/4 x 20 x 5/8
23	127501	Shaft, Pitman
24	109816X	Nyliner, Snap-in
25	124036X	Bracket, Steering
26	12000029	Ring Klip
27	136874	Gear, Sector
28	6266H	Bearing Race Thrust Harden
29	17490612	Screw, Hex Washer Head Thread Rolling 3/8-16 x 3/4 Type TT
30	10040600	Washer Lock 3/8
31	73610600	Nut, Fin Hex 3/8-24 Unf
32	130465	Rod, Tie
33	126847X	Bushing
34	19131416	Washer 13/32 x 7/8 x 16 Ga.
35	76020412	Pin, Cotter 1/8 x 3/4
36	132196	Bushing, Steering
37	17431008	Screw, Hex Tapping #10-16 x 1/2 Type ABTPS
38	133742	Insert, Steering Wheel
39	19133808	Washer 13/32 x 2-3/8 x 8 Ga.
40	7810H	Locknut, Center 3/8-24
41	104820X	Adapter, Steering Wheel
42	124418X	Boot, Steering
43	121749X	Washer 25/32 x 1-1/4 x 16 Ga.
44	121748X	Washer
45	12000029	Ring Klip
46	121232X	Cap, Spindle
47	6855M	Fitting Grease

NOTE: All component dimensions given in U.S. inches.
1 inch = 25.4 mm

REPAIR PARTS

12 HP 38" TRACTOR -- MODEL NUMBER CH1238A

SEAT ASSEMBLY

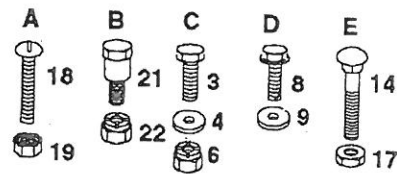
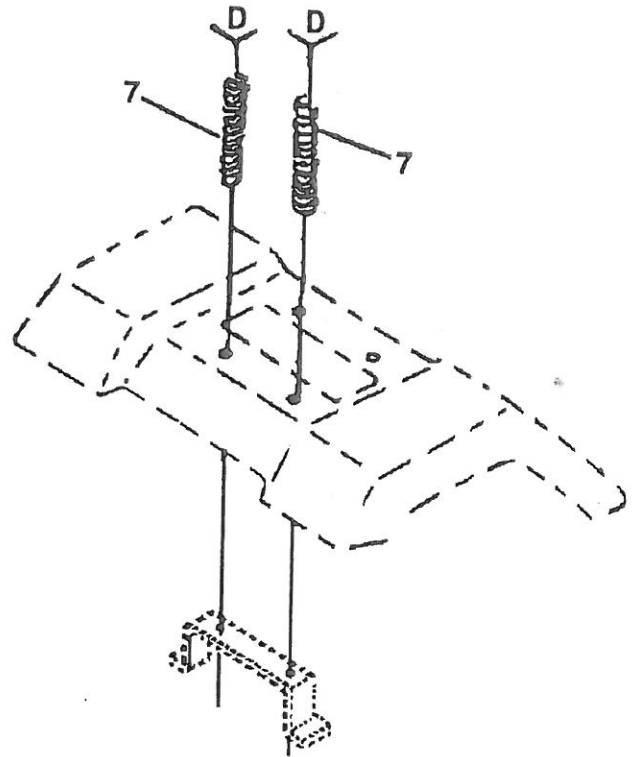
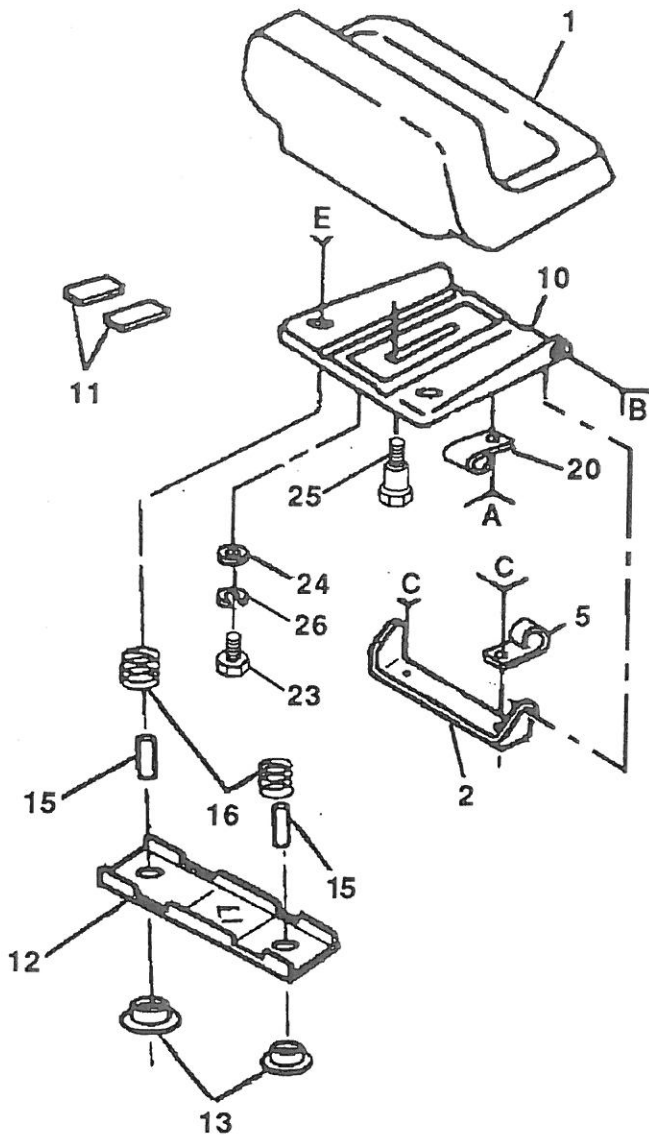

KEY NO.	PART NO.	DESCRIPTION
1	127427	Seat V-350
2	126656X	Bracket Pivot Seat 8 720
3	74760612	Bolt Fin Hex 3/8-16unc X 3/4
4	19131610	Washer Flat 13/32 X1 X 10 Ga
5	2751R	Clip Line Fuel 13/32 Mtg Hole
6	73680600	Nut Crownlock 3/8-16 Unc
7	124181X	Spring Seat Cprsn 2 250 Blk Zi
8	17490616	Screw Thdrol 3/8-16 X 1 Ty-tt
9	19131614	Washer 13/32 X 1 X 14 Ga
10	131451	Pan Seat
11	121251X	Strip Foam Gray Or Black
12	121246X	Bracket Mounting Switch
13	121248X	Bushing Snap Blk Nyl 50 Id
14	72050411	Bolt Rdhd Sht Nk 1/4-20x1-3/8

KEY NO.	PART NO.	DESCRIPTION
15	134300	Spacer Split 28x 96 Yel Zinc
16	121250X	Spring Cprsn 1 27 Blk Pnt
17	123976X	Nut Lock 1/4 Lge Flg Gr 5 Zinc
18	74641008	Screw SLTD Pan Hd #10-32 X 1/2
19	73951000	Nut Keps #10-32 Unf
20	4171R	Clip Insulated 11/32 Mtg Hole
21	105529X	Bolt Shoulder 5/16-18 Unc Blkz
22	73680500	Nut Crown Lock 5/16-18
23	74780814	Bolt Fin Hex 1/2-13 X 7/8 Gr 5
24	19171912	Washer 17/32 X 1-3/16 X 12 Ga
25	127018X	Bolt Shoulder 5/16-18 X 62
26	10040800	Washer Lock Hvy Hlcl Spr 1/2

NOTE: All component dimensions given in U.S. inches
1 inch = 25.4 mm

REPAIR PARTS

12 HP 38" TRACTOR -- MODEL NUMBER CH1238A

ENGINE

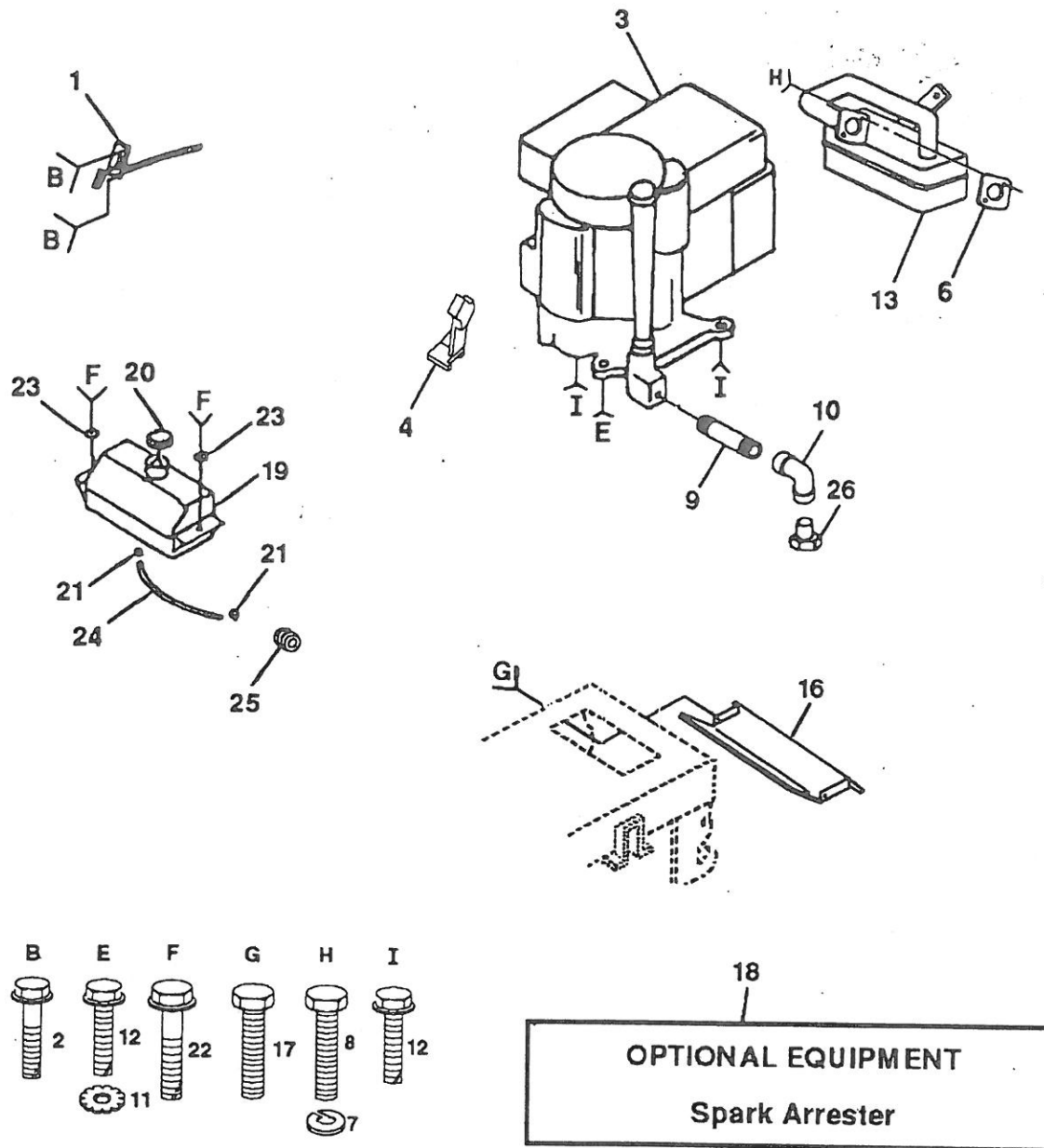

KEY NO.	PART NO.	DESCRIPTION
1	132623	Control Throttle
2	17720410	Screw Hex Thd Cut 1/4-20x5/8 T
3	-----	Engine B&S 12HP Model #283707
4	127951	Stop Throt 3000 Rpm
6	125593X	Gasket Eng 1 313 Id Tin Plated
7	10040500	Washer Lock Hvy Hlcl Spr 5/16
8	71070512	Screw Hexhd Cap 5/16-18x3/4
9	13280324	Nipple Pipe 3/8 Npt X 3"
10	13200300	Elbow Std 90 Degree 3/8-18 Npt
11	11050600	Washer Lock Ext Tooth 3/8
12	17490620	Screw Thdrol 3/8-16x1-1/4 TYTT
13	137348	Muffler LT B&S 12/12 5 HP
16	128953	Shield Heat Browning LT/YT

KEY NO.	PART NO.	DESCRIPTION
17	17021008	Screw Tap Hex #10-24unc X 1/2
18	137180	Kit Spark Arrestor 1 25
19	109202X	Tank Fuel Front 1 25
20	123549X	Cap Asm Fuel W/sym Vented
21	123487X	CLAMP Hose Blk
22	17490412	Screw Thdrol 1/4-20 x 3/4
23	19091416	Washer 9/32 x 7/8 x 16 Ga.
24	8548R	Line Fuel 13"
25	124028X	Bushing Snap Nyl Blk Fuel Line
26	-----	Plug Oil Drain (Order From Engine Manufacturer)

NOTE: All component dimensions given in U.S. inches
1 inch = 25.4 mm

REPAIR PARTS

12 HP 38" TRACTOR -- MODEL NO. CH1238A

MOWER

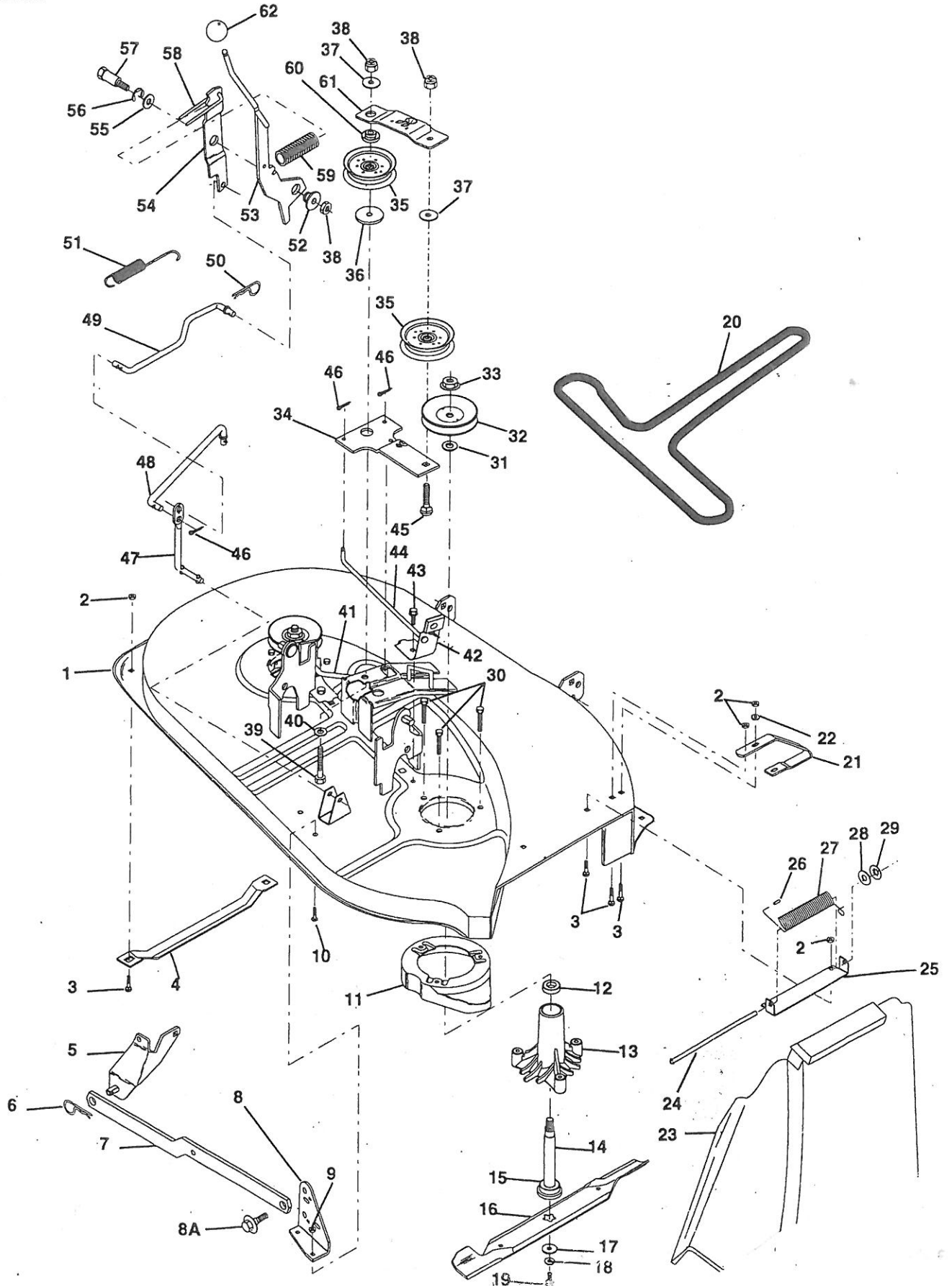

REPAIR PARTS

12 HP 38" TRACTOR -- MODEL NO. CH1238A

MOWER

KEY NO.	PART NO.	DESCRIPTION	KEY NO.	PART NO.	DESCRIPTION
1	138026	Mower Housing	34	133840	Arm Idler 38"
2	73680500	Nut Crown Lock 5/16-18	35	131494	Pulley Idler Flat 3 060
3	72140506	Bolt Rdhd Sqnk 5/16-18unc X3/4	36	122052X	Spacer Retainer Pm Mower
4	7631J	Runner Mower LH 10 00	37	19131612	Washer 13/32 X 1 X 12 Ga
5	138017	Bracket assembly, front	38	73680600	Nut Crownlock 3/8-16 Unc
6	4939M	Retaining spring	39	74600636	Bolt Hex 3/8-16 X 2-1/4
7	130832	Arm, suspension rear	40	19131612	Washer 13/32 X 1 X 12 Ga
8	138440	Bracket Deck Sway Bar	41	131289	Rod Brake Mandrel LH 4 856
8A	132827	Bolt, Shoulder 5/16-18	42	130840	Brake Asm Mower Vented
9	73800500	Hex locknut 5/16-18	43	17490512	Screw Thdrol 5/16-18 X 3/4 TYT
10	72140506	Carriage bolt 5/16-18 x 3/4	44	131288	Rod Brake Mandrel RH 10 744
11	136929	Stripper Mower Vented	45	72110614	Bolt Rdhd 3/8-16uncx1-3/4 Gr5
12	110485X	Bearing Ball Mandrel	46	76020312	Pin Cotter 3/32 X 3/4 Cad
13	128774	Housing Mandrel Vented(machd)	47	133551	Rod Pivot W/nibs
	137645	Shaft Asm W/lower Bearing	48	133504	Rod Clutch Secondary W/nibs
	129895	Bearing Ball #6204 (Mandrel)	49	134666	Rod Clutch Primary 38/42
16	131322	Blade Mower Euro. 38	50	4497H	Spring Retainer 1" Zinc/cad
17	129962	Washer Hard Blade Mower Vented	51	131870	Spring Return
18	10030600	Washer Lock Hvy 3/8 Unplated	52	127498	Bushing 747 Od X 794 Lg Brass
19	850857	Bolt 3/8-24x1 25 Gr8 Patched	53	133573	Arm Asm Clutch Primary
20	131290	V-Belt Mower 88 12 Black 38"	54	127847	Arm Clutch Secondary
21	128772	Runner RH 38"	55	121748X	Washer 25/32 X 1-5/8 X 16 Ga
22	19111216	Washer 11/32 X 3/4 X 16 Ga	56	12000029	Ring Klip #t5304-75
23	106736X	Shield Deflector Mower 38"blk	57	128903	Bolt Shoulder 3/8-16 Unc 1 44
24	106735X	Rod Hinge Brt/blk Zinc 9 88 Lg	58	127845	Keeper Spring 4 000
25	137607	Bracket Deflector Mower	59	128759	Spring Clutch Mower 2 750 Zinc
26	105304X	Cap Sleeve 80x 112 Blk Mower	60	133502	Spacer Arm Idler Upper Hdn 42"
27	123713X	Spring Deflector	61	133503	Stiffener Arm Idler Upper 42"
28	19111016	Washer 11/32 X 5/8 X 16 Ga	62	7803J	Knob Rd 3/8-16 Plstc Thds
29	110452X	Nut Push Phos & Oil	--	138360	Deck Serv 38"mech
30	78158	Bolt 5/16-18 X 1 25 T/t	--	130794	Mandrel Asm Service (Includes Key Nos. 12-15, 17-19, 31 and 33)
31	129963	Washer Spacer Mower Vented			
32	129206	Pulley Mandrel 38" Single			
33	137226	Nut 9/16top Lock Flng Oil Dip			

NOTE: All component dimensions given in U.S. inches - 1 inch = 25.4 mm.

REPAIR PARTS

12 HP 38" TRACTOR - - MODEL NUMBER CH1238A

MOWER LIFT

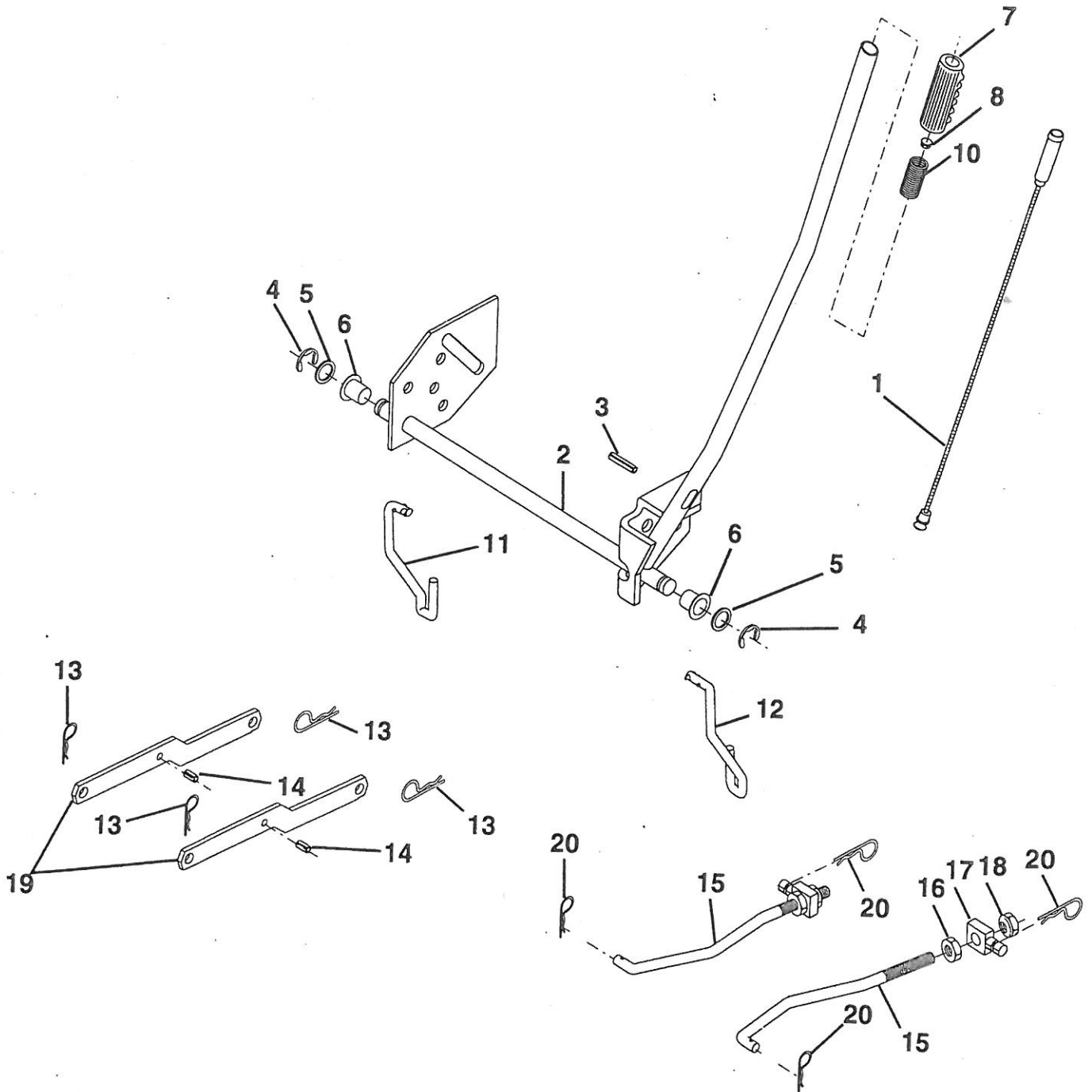

REPAIR PARTS

12 HP 38" TRACTOR - - MODEL NUMBER CH1238A

MOWER LIFT

KEY NO.	PART NO.	DESCRIPTION
1	136973	Wire Asm Inner W/plunger 17 32
2	122507X	Shaft Asm Lift 9 680
3	105767X	Pin Groove 1 500 Zinc
4	12000002	E Ring #5133-62
5	19211621	Washer PLTD 21/32 X 1 X 21ga
6	120183X	Bearing Nylon Blk 629 Id
7	109413X	Grip Handle Bicycle Matte Blk
8	124385X	Button Plunger Yellow
10	122512X	Spring Cprsn 3 750 Oiled
11	134619	Link Lift LH Fixed Length
12	135388	Link Lift RH Fixed Length
13	4939M	Retainer Spring
14	135563	Pin Roll SLT 5/16 X 1 25 Blk O
15	127218	Link Front
16	73350800	Nut Jam Hex 1/2-13 Unc
17	130171	Trunnion Blk Zinc
18	73800800	Nut Lock W/wsh 1/2-13unc
19	130832	Arm Suspension Rear
20	3146R	Retainer Spring

NOTE: All dimensions given in U.S. inches. 1 inch = 25.4 mm

REPAIR PARTS

12 HP 38" TRACTOR -- MODEL NUMBER CH1238A

TRANSAXLE DANA -- MODEL NUMBER 4360-48

TRANSAXLE

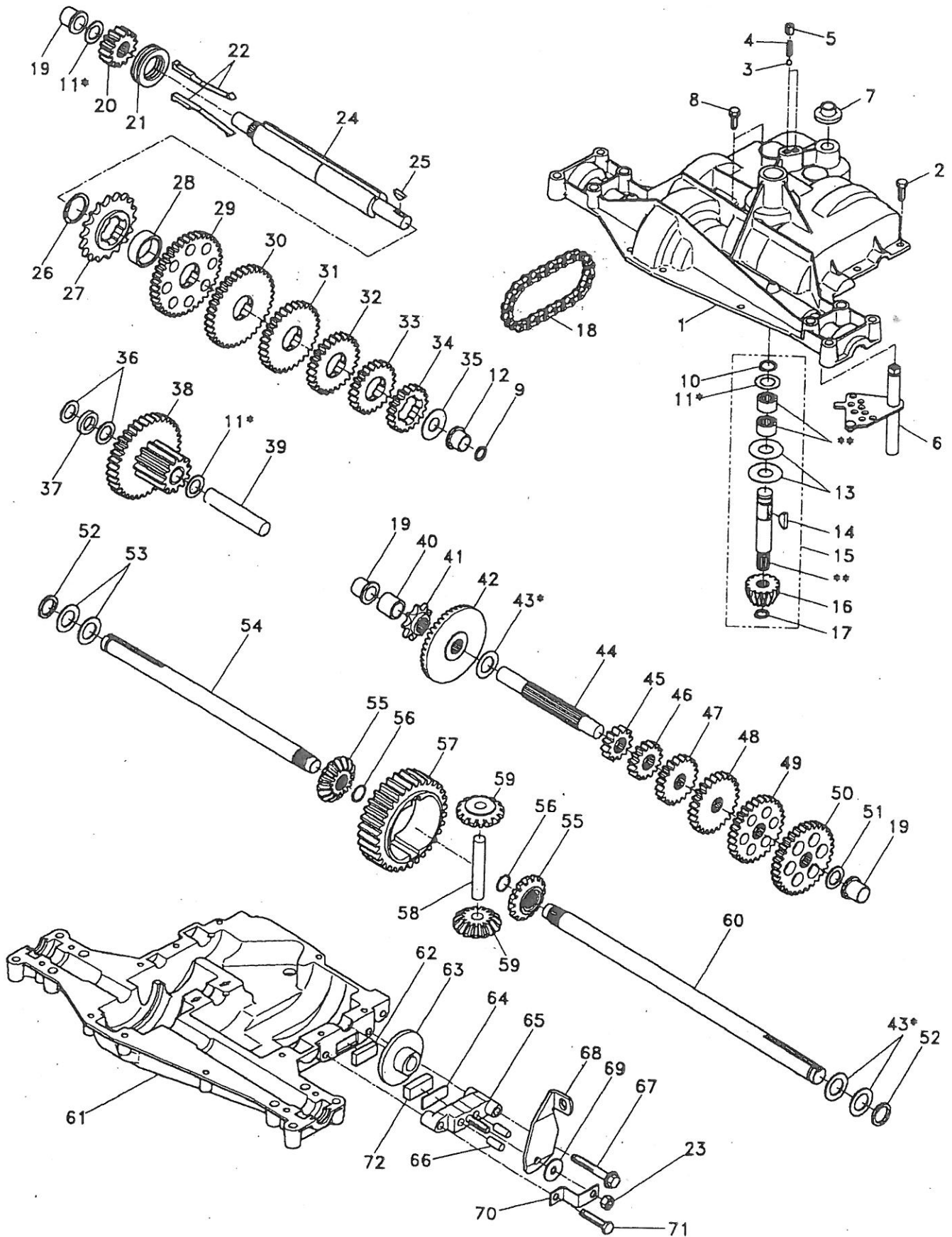

REPAIR PARTS

12 HP 38" TRACTOR -- MODEL NUMBER CH1238A

TRANSAXLE DANA -- MODEL NUMBER 4360-48

TRANSAXLE

KEY PART NO. NO.	DESCRIPTION	KEY PART NO. NO.	DESCRIPTION
1 138248	Housing, Upper	41 105928X	Sprocket, 9 Teeth
2 2274J	Screw, Self-Tapping, Large 1/4-20 x .734	42 110084X	Gear, Bevel, 42 Teeth
3 134400	Ball, Detent	43 134394	* Assembly, Kit, Shim .750 Shaft
4 105904X	Spring, Detent	44 120473X	Shaft, Drive
5 105905X	Screw, Set	45 105933X	Gear, Spur, 12 Teeth
6 138235	Kit, Shifter Assembly	46 106151X	Gear, Spur, 15 Teeth
7 134399	Boot, Shifter	47 120407X	Gear, Spur, 20 Teeth
8 134791	Screw, Tapping w/Sealer	48 106589X	Gear, Spur, 25 Teeth
9 138241	Square Ring	49 120408X	Gear, Spur, 28 Teeth
10 2267J	Ring, Retaining	50 105937X	Gear, Spur, 31 Teeth
11 134793	* Assembly, Kit, Shim .625 Shaft	51 2226J	Washer, Plain .632 x 1.00 x .060
12 138240	Bearing, Flange	52 134401	Washer, Neoprene
13 120415X	Washer, Plain .632 x 1.38 x .046	53 2264J	Washer, Plain .758 x 1.25 x .031
14 2257J	Key, Woodruff, #9	54 120474X	Axle, L.H.
15 138234	Assembly, Kit, Input Shaft	55 110081X	Gear, Miter, 15 Teeth
16 110078X	Pinion, Bevel, 14 Teeth	56 105941X	Ring, Retaining
17 105909X	Ring, Retaining	57 110071X	Gear, Spur, 32 Teeth
18 105910X	Chain, 24 Pitches	58 120952X	Shaft, Cross
19 105911X	Bearing, Flange	59 110082X	Gear, Miter, 15 Teeth
20 138242	Gear, Spur, 14 Teeth	60 120475X	Axle, R.H.
21 138246	Collar, Clutch	61 138247	Housing, Lower
22 138236	Assembly, Kit, Clutch Keys	62 120961X	Puck, Friction
23 73810500	Locknut 5/16-24	63 7294J	Disc, Brake
24 138243	Shaft, Intermediate	64 108989X	Spacer
25 2244J	Key, Woodruff, #61	65 120953X	Jaw, Brake
26 105916X	Ring, Retaining	66 120954X	Pin, Dowel
27 120470X	Sprocket, 18 Teeth	67 134799	Screw, Self-Tapping, Large 5/16-18 x 2.25
28 110070X	Spacer	68 138244	Lever, Actuating
29 108977X	Gear, Spur, 37 Teeth	69 108996X	Washer, Plain .321 x 1.00 x .055
30 109254X	Gear, Spur, 35 Teeth	70 120956X	Bracket, Anti-Rotation
31 120405X	Gear, Spur, 30 Teeth	71 106596X	Screw, Self-Tapping, Large 5/16-18 x 1.44
32 108980X	Gear, Spur, 25 Teeth	72 120951X	Puck, Friction
33 120406X	Gear, Spur, 22 Teeth	73 120416X	Grease
34 134796	Gear, Spur, 19 Teeth		
35 105925X	Washer, Plain .640 x 1.37 x .061		
36 2232J	Washer, Plain .632 x 1.00 x .026		
37 108978X	Spacer .630 x 1.00 x .169		
38 110079X	Assembly, Gear, Combination of 12 Teeth and 35 Teeth		
39 124639X	Shaft, Idler		
40 120472X	Spacer .635 x .875 x .755		

* Use in combinations to maintain proper clearances

** Order Key No. 15

NOTE: All component dimensions given in U.S. inches
1 inch = 25.4 mm