



Operator's Manual

user manual, maintenance instructions and spare parts



26B Blower / 28BV Blower Vacuum

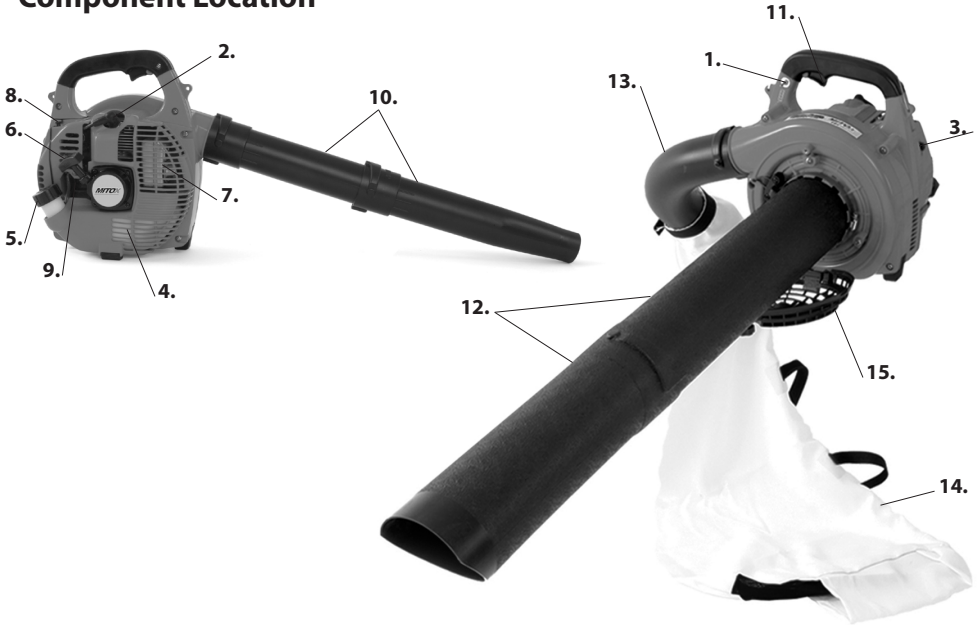

Read this manual carefully before operating the machine
Original Instructions Version October 13

Component Location



- 1. Ignition Switch** ON-OFF toggle switch. Switch to ON before starting. Switch to OFF to stop engine
- 2. Spark Plug** Provides spark to ignite 2-stroke fuel mixture
- 3. Air Cleaner** Replaceable air filter
- 4. Fuel Tank** Contains fuel and fuel filter
- 5. Fuel Cap** Seals fuel inside fuel tank
- 6. Recoil Starter** Pull to start engine
- 7. Muffler** Controls exhaust emissions and noise
- 8. Choke** To assist cold starting. Fully extend to close choke.  Push in to open choke. 
- 9. Primer Bulb** Draws fuel from fuel tank and purges air from the carburetor prior to starting.
- 10. Blower Pipes** Two parts lock together to form air discharge pipe.
- 11. Throttle Lever** Pull to increase engine speed.
- 12. Vacuum Tube** Two parts lock together to form air intake pipe. Vacuums in debris to be shredded.
- 13. Vacuum Elbow** Discharges shredded materials into collection bag.
- 14. Collection Bag** Collects shredded materials with zip to empty.
- 15. Side Cover** Must be closed when in blower mode.

PRODUCT DESCRIPTION

This Blower/Vacuum is a 2 stroke fast running power tool and is designed to be used in a domestic application for blowing or vacuuming leaves and cut lawn. It can be easily converted into a blower.

Important

The information contained in this manual describes machines available at the time of production. While every attempt has been made to give you the very latest information about your 26B/28BV, there may be some differences between your machine and what is described here. We reserve the right to make changes in production without prior notice, and without obligation to make alterations to machines previously manufactured.

Before using this product, consult local regulations concerning noise restrictions and hours of operation.

- This product has been designed to be used as a Blower/Vacuum power tool as described previously and it should never be used for any other purpose; doing so could result in unforeseen accidents and injuries occurring. Only approved Mitox accessories should be used with this product.
- This Blow/Vac is equipped with extremely sharp blades, always wear sturdy gloves when handling the blades and fit the safety guards when not in use.
- When using the Blow/Vac, grip the handles firmly with both hands, place your feet slightly apart so your weight is distributed evenly across both legs, and always maintain a steady even posture while working. Do not use on ladders or if the ground surface is slippery or uneven.

Work Clothing and Safety Equipment

When using the product, you should wear proper clothing and protective equipment:

- Helmet
- Protection goggles or face protector
- Ear protectors
- Thick work gloves
- Non-slip sole work boots
- When using your blower, always wear strong, durable, work clothing; shirts should be long-sleeved and trousers should be full-length. No loose clothing / ties or jewellery.
- Dust mask

Warnings in the Manual

This manual contains special “attention statements” surrounded by boxes and preceded by the triangular Attention Symbol:



WARNING!

A statement preceded by the word "WARNING" contains information that should be acted upon to prevent serious bodily injury.



CAUTION!

A statement preceded by the word "CAUTION" contains information that should be acted upon to prevent machine damage.

Additional attention statements that are not preceded by the Attention Symbol are:



IMPORTANT

A statement preceded by the word “IMPORTANT” is one that possesses special significance.



NOTE

A statement preceded by the word “NOTE” contains information that is handy to know and may make your job easier.



Read and follow this manual. Failure to do so could result in serious injury.



Wear eye and hearing protection at all times during the operation of this machine



DO not operate this machine if you are tired, ill or under the influences of alcohol, drugs, or Medicine.

Product Description

The operational procedures described in this manual are intended to help you get the most from your machine and also to protect you and others from harm. These procedures are general guidelines only, and are not intended to replace any safety rules/laws that may be in force in your area.

If you have any questions regarding your blower/ vacuum, or if you do not understand something in this manual, your dealer will be glad to assist you.

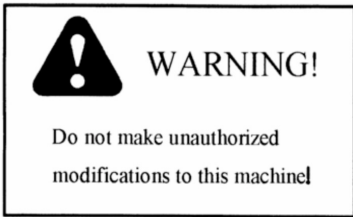

Specifications

Model.....	26B / 28BV
Dimensions(LxWxH).....	845x340x350(mm)
Engine Type	2 cycle air cools gas engine, vertical cylinder
Bore & Stroke	34x28(mm)
Displacement.....	25.4cc
Fuel.....	Gasoline /oil mixture 25:1
Carburettor.....	Walbro diaphragm-type with primer pump
Ignition.....	All transistor electronic ignition system
Spark plug.....	NGK BPMR7A
Starting.....	Recoil starter
Stopping.....	Grounding
Fuel Tank Capacity.....	0.65 litres
Exhaust system.....	low dB; spark-arrestor muffler
Air Cleaner Type.....	Semi-wet
Weight (dry; with vacuum tubes).....	6.3kg
Sound power values.....	≤105dB(A)

Assembling the Vacuum

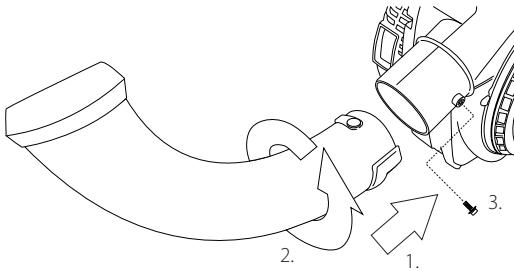

1. Fit the Vacuum elbow tube over the blower discharge port, aligning the channels in the tube over the locking pin.
2. Twist the Vacuum elbow tube to engage the locking pin as illustrated.
3. Lock the tube in place using 1 x M5x10 screw.

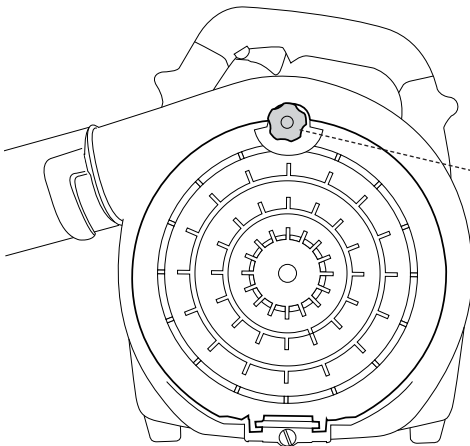

Open the side cover using the thumbscrew.

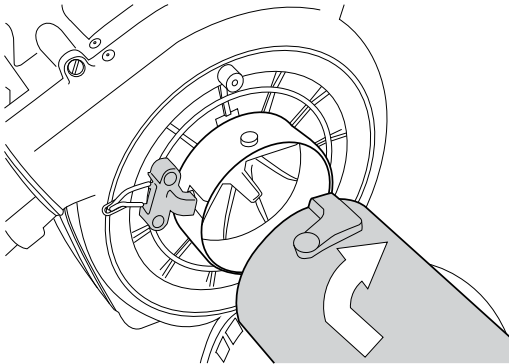

Fit the upper vacuum tube over the vacuum intake port, aligning the channels in the tube over the locking pin.

Twist the upper vacuum tube to engage the locking pin as illustrated.

Attach the lower vacuum tube to the upper vacuum tube using the same method.

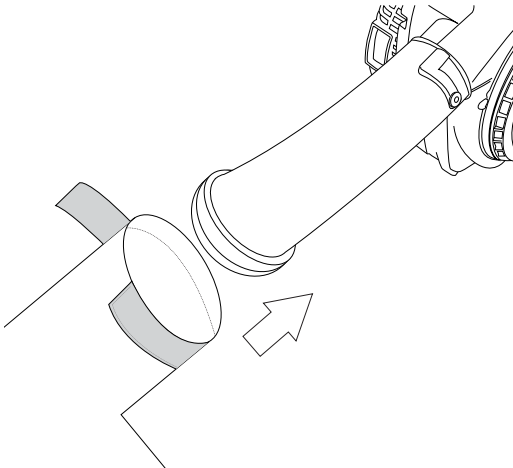

Fit the collection bag over the Vacuum elbow tube using the velcro fastener.

Assembling the Blower

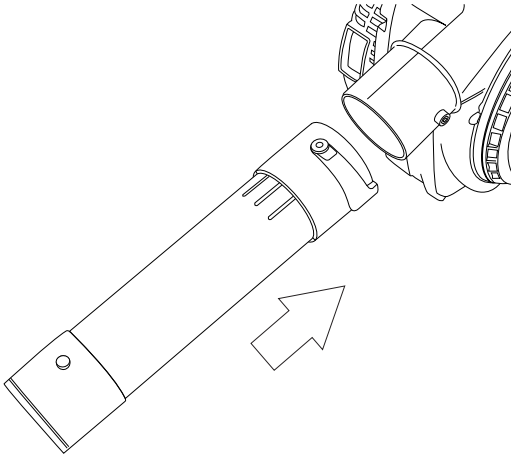

Fit the straight blower tube over the blower discharge port, aligning the channels in the tube over the locking pin.

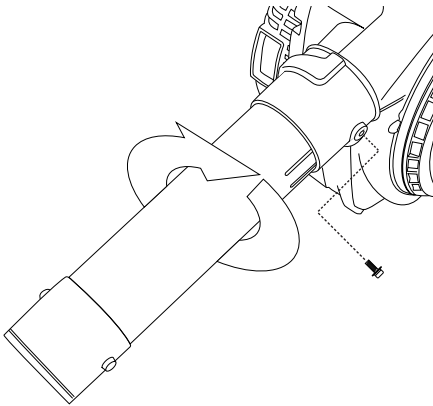

Twist the straight blower tube to engage the locking pin as illustrated. Lock the tube in place using 1 x M5x10 screw.

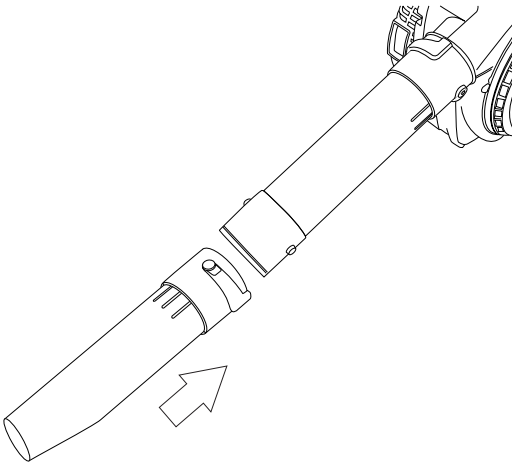

Fit the tapered blower tube over the straight blower tube, aligning the channels in the tube over the locking pins.

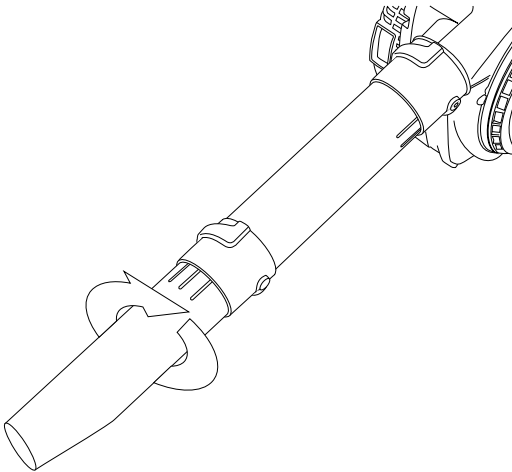

Twist the tapered blower tube to engage the locking pins as illustrated. Note the tapered discharge chute is marked with a TOP side.

Important

Blower tube installation affects both blower Balance and performance! The tube and Nozzle are correctly installed when the label "TOP" is visible to the operator during normal operation.

Two-Stroke Fuel



Fuel is very flammable. Do not smoke or bring any flame or sparks near fuel.

Always stop the engine and allow it to cool before refuelling.

Refuel outdoors on bare ground, restart engine at least 5m away from the refuelling stop.

The engine is lubricated by oil mixed into petrol. Prepare a mixture of unleaded petrol and semi-synthetic two-stroke oil that meets the specifications of: API TC, ISO-L-EGC, JASO FC (Low Smoke) oil.

Recommended mixing ratio is 25:1.

FUEL WITH NO OIL (RAW PETROL) will cause severe damage to the engine which is not covered by manufacturer's warranty.

Use fresh, unleaded petrol (95 RON) and semi-synthetic oil specially made for high performance two-stroke engines. Mix in a ratio of 25 parts petrol to 1 part of oil.

By using two-stroke oil specially made for two-stroke engines you will reduce the formation of ash and carbon deposits on the spark plug, piston, exhaust muffler and cylinder as well as reducing emissions of harmful exhaust gases.

Oil FOR 4-CYCLE ENGINES should not be used as two-stroke lubrication oil as it can cause fouling of the spark plug, exhaust port blocking, piston ring sticking and other internal engine damage.

Fuel Storage

Mixed two-stroke fuel which has been left unused for a period of one month or more may damage the carburettor and result in the engine failing to start or operate correctly.

When storing the grass trimmer for a period of more than one month, empty the fuel tank, and run the engine to empty the carburettor of fuel.

Two stroke fuel can cause deterioration of rubber and/or plastic components during prolonged storage.

It is important to only use good quality, fresh fuel mix.



CAUTION!

Never attempt to mix fuel in the machine fuel tank! Always mix all fuels in a clean, approved container!

Some gasoline contain alcohol as an oxygenate! Oxygenated fuels may cause increased engine operating temperatures! Under certain conditions, alcohol-based fuels may also reduce the lubricating qualities of some mixing oils! Never use any fuel containing more than 10% alcohol by volume! When an oxygenated fuel must be used, fuel containing an ether-based oxygenates such as MTBE is to be preferred over alcohol!

Whenever possible, use 2-cycle engine oil or equivalent oil mixed at a 25:1 ratio. Be aware that generic oils and some outboard mixing oils may not be intended for use in high-performance air cooled 2-cycle engines, and should never be used in your engine machine.

Fuelling

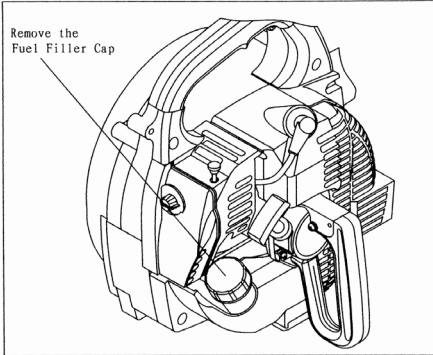

Shake the fuel container to thoroughly mix the two-stroke oil and petrol.

Clean dirt from around the fuel cap before removing.

Pour two-stroke fuel into the fuel tank with a filtered funnel, up to 80% of the fuel tanks capacity.

Replace the fuel cap and tighten securely. Spilled fuel must be wiped away from the blower before starting the engine.

Move at least 5m away from the refuelling area before restarting the engine.



When refilling the tank, always turn off the engine and allow it to cool down. Take a careful look around to make sure that there are no sparks or open flames anywhere nearby before refuelling.



WARNING!

Danger of fire and burn injury!

- **Always** use extreme care when handling fuel! Fuel is highly flammable!
- **Never** operate this blower if fuel system components are damaged or are leaking!
- **Never** attempt to refuel the engine while it is running!
- **Never** attempt to refuel a hot engine! Always allow the blower engine to cool before fuelling!
- **Never** smoke or light any fires near the blower or fuels!
- **Always** transport and store fuels in an approved container!
- **Never** place flammable material close to the engine muffler!
- **Never** operate the blower without a properly functioning muffler and spark arrestor installed!
- **Never** operate the blower unless it is properly assembled and in good working condition!

Starting the Machine



WARNING!

Danger from rotating impeller! The impeller will rotate whenever the machine is operated! Never operate this machine unless the intake cover and machine tubes are properly installed and in good working order!

Danger from thrown dust or debris! Always wear eye protection when operating this machine! Never direct the machine stream toward people or animals!

Never operate this machine unless all controls are properly installed and in good working order.



WARNING!

The recoil starter can be damaged by abuse!

- < Never pull the starter cord to its full length!
- < Always engage the starter before cranking the engine!
- < Always rewind the starter cord slowly!



Never operate the machine if the tubes are missing or damaged!

IMPORTANT !

A two-position "ON-OFF" switch located on the left of the machine handle grip controls the engine ignition.

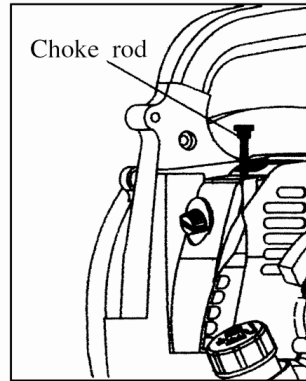
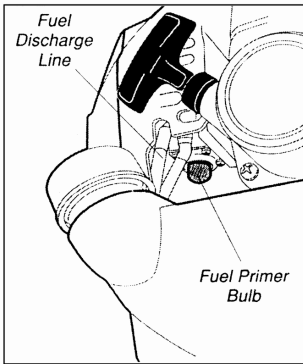
Cold Engine Starting Procedure



1. Prime the fuel system by repeatedly depressing the fuel primer bulb until no air bubbles are visible in the fuel discharge line.
2. Cold Engine Only. Choke the engine by pulling the choke control to the fully extended position (choke is closed). 
3. Set the ignition switch to the ON position.
4. Slowly pull the recoil starter handle until engagement of the pawls with the flywheel is felt.
5. While holding the unit, pull out the starter rope firmly until engine fires (indicated by a 'cough' from the engine).
6. Push the choke rod back in (choke is open). 
7. Pull the starter rope until the engine starts.
8. Allow the engine to warm up before use.

Hot Engine Starting Procedure

Set the ignition switch to the ON position .

Pull the starter rope until the engine starts.

If the engine does not start after 5 pulls, use the cold start procedure.

Overchoking

Should the engine become flooded due to overchoking, turn the ignition switch off, unscrew the spark plug, wipe it dry or replace.

Stopping the Engine

Set the engine to idling by releasing the throttle lever.

Set the ignition switch to the off position OFF.

If the engine fails to stop, set the choke lever to the closed position to stall the engine; do not use the machine until the ignition switch is repaired.

Adjusting the Engine Idle Speed

1. Start the engine by following the procedures described on the preceding pages.
2. Run the engine at idle speed until operating temperature is reached (2-3 minutes).
3. Use a screwdriver to adjust the engine idle speed to 2300-2500r/min.

Turn the idle screw clockwise to increase engine idle speed.

Turn the idle screw counterclockwise to decrease engine idle speed.

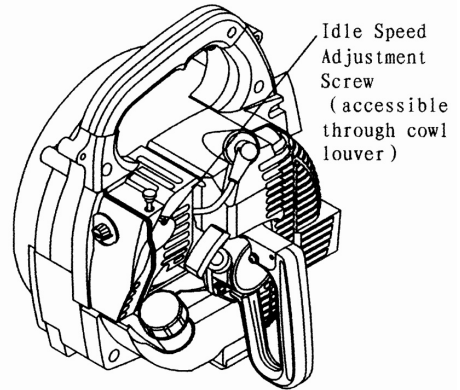

IMPORTANT !

Machine tubes and intake cover must be installed while adjusting engine idle! Engine idle speed will also be affected if either the intake cover or machine tubes are blocked, damaged or incorrectly installed!

IMPORTANT !

If the engine continues to run with the ignition switch in the "OFF" position, stop the engine by pulling the choke control out to the fully closed position.

A clean and unrestricted airflow is essential to your machine's engine performance and durability! Before attempting any carburetor adjustments, inspect and clean the engine air cleaner as described on page 11 of this manual.

Using the Machine

As a general rule, try to operate your machine at the lowest throttle setting necessary to get the job done:

- Use low throttle settings when clearing lightweight materials from around lawns or shrubbery.
- Use medium to higher throttle settings to move lightweight grass or leaves from parking lots or walkways.
- Use full throttle when moving heavy loads such as dirt or snow.

Safe operation

- (1) Machine noise increases at higher throttle settings. Always use the lowest throttle setting required to get the job done.
- (2) Never operate the blower when visibility is poor.
- (3) Always wear eye protection such as face shield or goggles while operating this machine.
- (4) Wear a dust mask to reduce the risk of inhalation injuries.
- (5) Wear close-fitting clothing to protect your legs and arms.
- (6) Wear hearing protection when operating this machine.
- (7) Never operate the blower if any component parts are damaged, loose, or missing.

Using the Vacuum

Always be aware of the strength and direction of stream. Never direct the blower discharge stream toward people or animals.



Using the Blower

Always be aware of the strength and direction of stream. Never direct the blower discharge stream toward people or animals.



Routine Maintenance



WARNING!

Before performing any maintenance on this machine, stop the engine and disconnect the spark plug wire!



CAUTION!

Dirty or damaged cooling system components may allow the engine to overheat, possibly causing serious engine damage!



CAUTION!

Operating the machine with loose, missing, or damaged components could allow the engine to overspeed, possibly causing serious engine damage!

Daily Maintenance

Remove dirt and debris from the blower exterior.

Inspect the engine, tank, and hoses for possible fuel leaks, and repair as necessary.

Inspect the engine cooling fins for accumulations of dirt or debris, and clean as necessary.

Inspect the entire machine for damage, loose or missing components or fastenings, and repair as necessary.

Every 10 Hours Use (MORE FREQUENTLY IN DUSTY CONDITIONS)

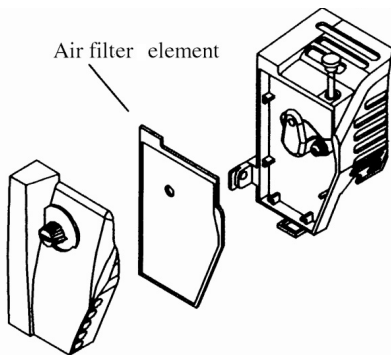

1. Loosen the air cleaner cover retaining screw, and remove the cover and filter element.
2. Inspect the element. If the element is distorted or damaged, replace it with a new one.
3. Wash the element in clean fuel, and squeeze or blow dry. Wash the air cleaner cover in clean fuel, and wipe or blow dry.
4. Install the element and cover, and then tighten the cover retaining screw.

Every 10/15 Hours Use



1. Use the spark plug wrench to remove the spark plug (turn counter-clockwise to remove).
2. Clean and adjust the spark plug gap to 0.6~0.7mm. Replace any damaged or visibly worn plug with a NGK BPMR7A or equivalent.
3. Install the spark plug finger-tight in the cylinder head, and then tighten it firmly with the spark plug wrench. If a torque wrench is available, torque the spark plug to 148-165 inch pounds.

Every 50 Hours Use (MORE FREQUENTLY IF YOU NOTE REDUCED PERFORMANCE)

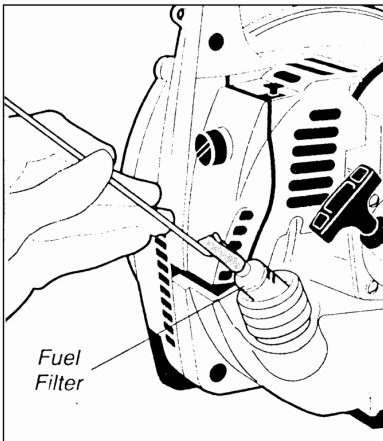

INSPECTION Inspect the entire machine and tubes for damage, including loose or missing components, and repair as necessary.

SPARK PLUG Replace the spark plug with a NGK BPMR7A , gapped to(0.6~0.7)mm.

FUEL FILTER Use a wire hook to extract the fuel filter from inside the fuel tank, and then remove and wash the filter element in clean fuel.

Before reinstalling the filter, inspect the condition of the fuel line. If damage or deterioration is noted, the vacuum should be removed from service until it can be inspected by a trained service technician.

COOLING SYSTEM Remove the engine cover (as described under "Spark Arrestor"), and use a wood or plastic scraper and a soft brush to remove dirt and debris from the cylinder fins and crankcase.



CAUTION!

Never allow dirt or debris to enter the cylinder bore!
Before removing the spark plug, thoroughly clean the spark plug and cylinder head area!
Allow the engine to cool before servicing the spark plug!
Cylinder tightening or loosening the spark plug while the engine is hot!
Incorrect spark plug installation can result in serious engine damage!

Spark Arrestor Maintenance

Hard starting or gradual loss of performance can be caused by carbon deposits lodged in the spark arrestor screen. For maximum performance, the spark arrestor screen should be periodically cleaned as follows:

1. Remove the spark plug.
2. Remove three self-tapping screws and two machine screws from the engine cover, and then gently move the engine cover aside.
3. Remove the three-spark arrestor retaining screws, and then remove the spark arrestor cover, screen, gasket, and chamber.
4. Use a plastic scraper or wire brush to remove carbon deposits from the arrestor screen, chamber, and cover.
5. Inspect the screen carefully, and replace any screen that has been perforated, distorted, or is otherwise unserviceable.
6. Install the chamber, screen, gasket and cover in the reverse order of disassembly, and then install and securely tighten the three cover retaining screws.
7. Install the engine cover, and verify that the fuel line connections are still tightly in place.
8. Install the engine cover retaining screws in the reverse order of removal, and tighten securely.
9. Install and tighten the spark plug, and reconnect the spark plug wire.

Storage (30 days or longer)

CLEANING Thoroughly clean the machine exterior.

INSPECTION Inspect the entire machine and tubes for damage, including loose or missing components, and repair as necessary.

FUEL Drain the fuel tank, and then clear the carburetor and lines by running the machine until it stops from lack of fuel.

LUBRICATION Remove the spark plug, and then pour approximately 1/4-oz of oil into the cylinder through the spark plug hole. Before reinstalling the spark plug, pull the recoil starter 2 or 3 times to distribute the oil over the cylinder walls.

AIR CLEANER Remove, clean, and reinstall the filter element as described under "daily maintenance."

STORAGE Store the machine in a clean, dry, dust-free environment.

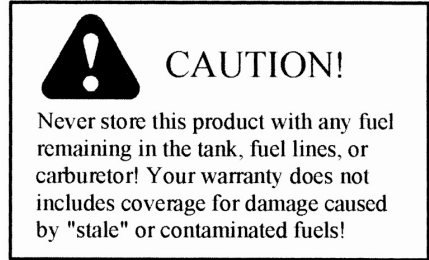

IMPORTANT!

- **After every use, check that all nuts, bolts and screws are securely fastened and tighten if necessary.**
- **In the event of an accident, breakdown or blockage, ensure the engine is turned off before any work is carried out to rectify this.**
- **Make sure the engine has stopped and is cool before performing any service to the machine. Contact with moving parts or hot muffler may result in a personal injury. Always wear heavy-duty gloves when handling the blades.**

Transportation

- Never transport the Blow/Vac with the engine running. An engine that is running could be accidentally accelerated causing the impeller to engage.
- Make sure the blade safety guards are in place when transporting the Blow/Vac.
- Ensure the Blow/Vac is secure when transporting in a vehicle and the tank is drained of fuel.

ENGINE DOES NOT START

What To Check Possible Cause Remedy

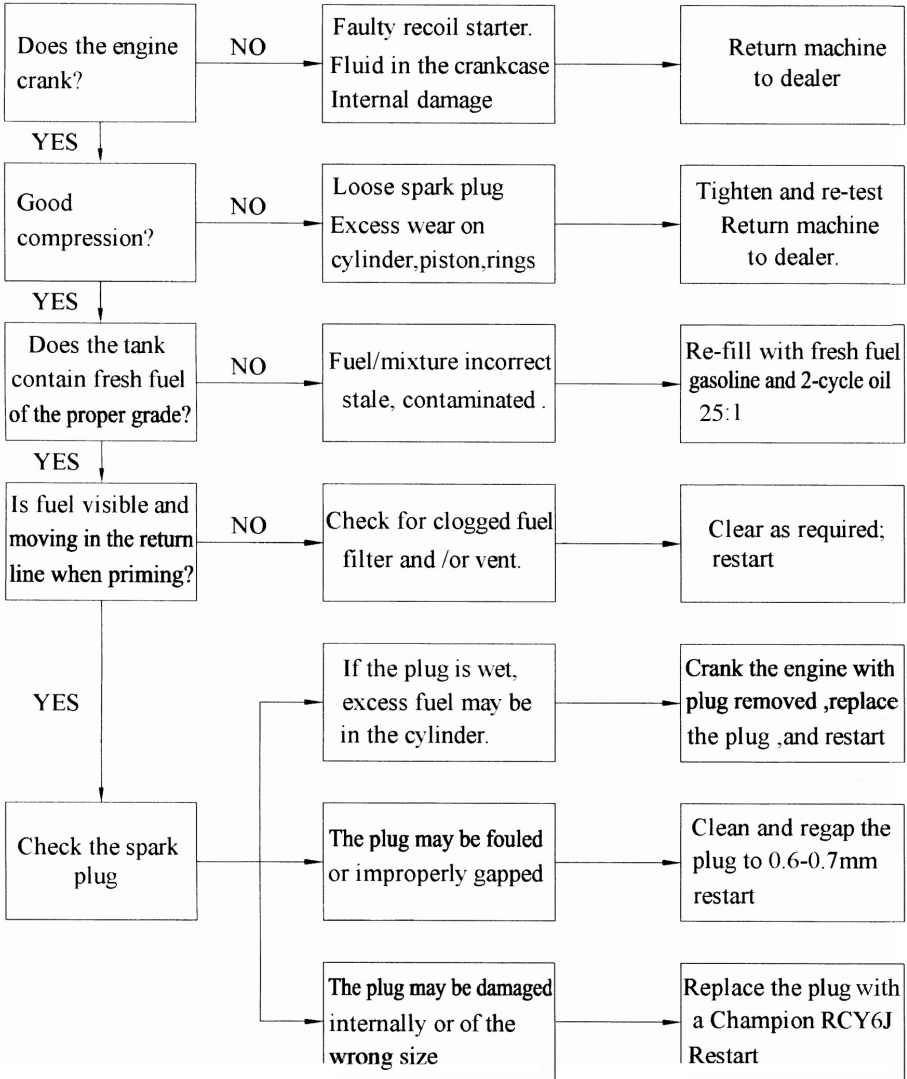

ADDITIONAL PROBLEMS

Symptom

Possible Cause

Remedy

Poor acceleration	Clogged air cleaner element.	Clean the element
	Clogged fuel filter.	Replace the fuel filter as required
	Carburetor mixture too lean	Return machine to the dealer
	Idle speed set too low	Adjust: 2300-2500rpm

Engine stops abruptly.	Fuel tank empty	Refuel
	Clogged fuel filter.	Clean or replace the fuel filter as required
	Water in the fuel	Drain ; replace with clean fuel
	Shorted spark plug or loose terminal.	Clean and replace spark tighten the terminal
	Ignition failure	Return machine to the dealer
	Piston seizure	Return machine to the dealer

Engine difficult to shut off.	Ground (stop)wire is disconnected, or switch is defective	Test and replace as required
	Overheating due to incorrect spark plug.	Correct plug: Champion RCY6J
	Overheated engine	Idle engine until cool.

Excessive vibration	Warped or damaged blower fan	Inspect and replace fan as required.
	loose bolt or fastener	Tighten as required.
	Internal engine damage	Return machine to dealer

LOW POWER OUTPUT

What To Check Possible Cause Remedy

Is the engine overheating?	Operate is overworking the machine	Use lower throttle setting
	Carburetor mixture is too lean	return machine to dealer.
	Improper fuel ratio	Re-fill with fresh fuel of the correct mixture gasoline and 2-cycle oil 25:1 ratio
	Fan , fan over ,cylinder fins dirty or damaged	clean ,repair or replace as necessary
	Carbon deposits on piston or in the muffler	Decarbonize

Engine is rough at all speeds.May also have black smoke and/or unburned fuel at the exhaust.	Clogged air cleaner element	service the air cleaner.
	loose or damaged spark plug	Tighten or replace
	Air leakage or clogged fuel line	Repair or replace filter and/or fuel line
	Water in the fuel	Drain the fuel dealer replace the fuel
	Piston seizure	Return machine to dealer.
	Faulty carburetor and / or diaphragm	Return machine to dealer.

Engine is knocking	Overheating condition	Idle enginer until cool; find reason for overheat
	Improper fuel	Check fuel octane rating; check for presence of alcohol in the fuel. Refuel as necessary
	Carbon deposits in the combustion chamber	Decarbonize

CONDITIONS OF WARRANTY

The manufacturer warrants the product against faulty materials and workmanship for a period of 2 years from the date of first purchase. The warranty is applicable when the product is used in a "home owner" application. If products are used for commercial or professional purposes, the warranty period is for 3 months from the date of first purchase. Warranty does not extend to failure due to fair wear and tear.

The manufacturer undertakes to replace, any spare parts that are classified as defective by an appointed Mitox service dealer. The manufacturer will not accept liability for the replacement of the machine, either partially or wholly, and /or consequential damages and /or interest charges either directly or indirectly.

Warranty does not cover failure due to:

Insufficient maintenance.

Incorrect fuel mixture and stale fuel.

Abnormal use or accidental damage.

Incorrect assembly, adjustment or operation of the product.

Spare parts that are subject to wear e.g. safety parts, blades, blade supports, bearings, cables, guards, deflectors, spark plugs, air filters etc.

Neither does warranty extend to:

Freight and packing costs.

Use of non-genuine spare parts i.e. those from another manufacturer.

Use of the machine for any other purpose than that for which it was designed.

Use and maintenance of the machine in a manner not described in the owner's manual.

As part of our policy of continuous product improvement, we reserve the right to alter or amend this specification without notice. As a result, the product may differ from the information contained herein but any alteration will only be implemented without notice if it is classified as an improvement to the above specification.

READ THE MANUAL CAREFULLY BEFORE OPERATING THE MACHINE

When ordering spare parts, please quote the part number, this can be found in the parts list included in this manual.

Retain the receipt of purchase without which no warranty can be offered.

Distributed by Mitox Garden Machinery

Wincanton Business Park

Wincanton

Somerset

BA9 9RS